



User's Guide

Multimedia Projector

EB-1775W

EB-1770W



EB-1760W

EB-1750





Notations Used in This Guide

- **Safety indications**

The documentation and the projector use graphical symbols to show how to use the projector safely. Please understand and respect these caution symbols in order to avoid injury to persons or property.

 Warning	This symbol indicates information that, if ignored, could possibly result in personal injury or even death due to incorrect handling.
 Caution	This symbol indicates information that, if ignored, could possibly result in personal injury or physical damage due to incorrect handling.

- **General information indications**

Attention	Indicates procedures which may result in damage or injury if sufficient care is not taken.
	Indicates additional information and points which may be useful to know regarding a topic.
	Indicates a page where detailed information regarding a topic can be found.
	Indicates that an explanation of the underlined word or words in front of this symbol appears in the glossary of terms. See the "Glossary" section of the "Appendix".  "Glossary" p.128
[Name]	Indicates the name of the buttons on the remote control or the control panel. Example: [Esc] button
Menu Name	Indicates Configuration menu items. Example: Select Brightness from Image . Image - Brightness

Notations Used in This Guide 2

Introduction

Projector Features 8

- List of Functions by Model 8
- Quick and Easy Set up, Projection, and Storage 8
 - Connecting with a USB cable and projecting (USB Display) 8
- Easy Image Correction 8
 - Adjusting the projected image to automatically fit into the screen frame - Screen Fit - (EB-1775W only) 8
 - Detecting projector movements and automatically correcting image distortion 9
- Useful Functions for Expanding the Scope of Your Presentations 9
 - Increasing projection content in wide (WXGA) screen (EB-1775W/EB-1770W/EB-1760W only) 9
 - Connecting to a wireless LAN and projecting images from the computer's screen (EB-1775W/EB-1770W/EB-1760W only) 9
 - Connecting a projector and a computer wirelessly with Quick Wireless Connection (EB-1775W/EB-1770W/EB-1760W only) 9
 - Making the most of the remote control 9

Part Names and Functions 10

- Front/Top 10
- Rear 11
- Base 12
- Control Panel 13
- Remote Control 14
 - Replacing the remote control batteries 17
 - Remote control operating range 17

Preparing the Projector

Installing the Projector 19

- Installation Methods 19
 - Installation methods 19

- Screen Size and Approximate Projection Distance 20

Connecting Equipment 21

- Connecting a Computer 21
- Connecting Image Sources 22
- Connecting USB Devices 23

Basic Usage

Projecting Images 26

- From Installation to Projection 26
- Automatically Detect Input Signals and Change the Projected Image (Source Search) 27
- Switching to the Target Image by Remote Control 28
- Projecting with USB Display 28
 - System Requirements 28
 - Connecting for the first time 29
 - Uninstalling 30

Adjusting Projected Images 31

- Automatically Adjust to Fit the Screen Frame - Screen Fit - (EB-1775W only) 31
- Correcting Keystone Distortion 33
 - Correcting automatically - Auto H/V-Keystone - (EB-1775W only) 33
 - Correcting automatically - Auto V-Keystone - (EB-1770W/EB-1760W/EB-1750 only) 34
 - Correcting manually - manual H/V-Keystone - 34
 - Correcting manually - Quick Corner - 34
- Adjusting the Image Size 36
- Adjusting the Image Position 37
- Adjusting the Horizontal Tilt 37
- Correcting the Focus 37
- Adjusting the Volume 38
- Selecting the Projection Quality (Selecting Color Mode) 38
- Setting Auto Iris 39
- Changing the Aspect Ratio 40
 - Changing methods 40
 - Changing the aspect ratio for video equipment images 40

Changing the aspect ratio for computer images 42

Useful Functions

Projection Functions 45

- Projecting Without a Computer (Slideshow) 45
 - Specifications for files that can be projected using Slideshow 45
 - Slideshow examples 45
 - Slideshow operating methods 46
 - Projecting the selected image 48
 - Projecting image files in a folder in sequence (Slideshow) 49
 - Playing a scenario 49
 - Operating procedures during scenario playback 49
 - Image file display settings and Slideshow operation settings 50
- Hiding the Image and Sound Temporarily (A/V Mute) 51
- Freezing the Image (Freeze) 52
- Pointer Function (Pointer) 52
- Enlarging Part of the Image (E-Zoom) 53
- Using the Remote Control to Operate the Mouse Pointer (Wireless Mouse) 54
- Setting the ID and Using the Remote Control 56
 - Setting the Projector ID 57
 - Setting the remote control ID 57
- Correcting Color when Projecting from Multiple Projectors 58
 - Summary of correction procedure 58
 - Correcting 58
- Saving a User's Logo 60

Security Functions 62

- Managing Users (Password Protect) 62
 - Kinds of Password Protect 62
 - Setting Password Protect 62
 - Entering the Password 63
- Restricting Operation (Control Panel Lock) 64
- Anti-Theft Lock 65

Configuration Menu

Using the Configuration Menu 67

List of Functions 68

- Configuration Menu Table 68
 - Network menu (EB-1775W/EB-1770W/EB-1760W only) 69
- Image Menu 70
- Signal Menu 71
- Settings Menu 73
- Extended Menu 74
- Network Menu (EB-1775W/EB-1770W/EB-1760W Only) 76
 - Notes on operating the Network menu 76
 - Soft keyboard operations 77
 - Basic menu 78
 - Wireless LAN menu 79
 - Security menu 80
 - Mail menu 82
 - Others menu 82
 - Reset menu 83
- Info Menu (Display Only) 84
- Reset Menu 84

Troubleshooting

Using the Help 87

Problem Solving 88

- Reading the Indicators 88
- When the Indicators Provide No Help 91
- Problems Relating to Images 92
 - No images appear 92
 - Moving images are not displayed (only the moving image portion turns black) 93
 - Projection stops automatically 93
 - The message "Not supported" is displayed 93
 - The message "No Signal" is displayed 93

Images are fuzzy, out of focus, or distorted	94
Interference or distortion appear in images	95
The image is truncated (large) or small, or the aspect is not suitable	95
Image colors are not right	96
Images appear dark	97
Problems when Projection Starts	97
The projector does not turn on	97
Other Problems	98
No sound can be heard or the sound is faint	98
The remote control does not work	98
I want to change the language for messages and menus	99
Email is not received even if a problem occurs in the projector (EB-1775W/ EB-1770W/EB-1760W only)	99

Maintenance

Cleaning	101
Cleaning the Projector's Surface	101
Cleaning the Lens	101
Cleaning the Air Filter	101
Replacing Consumables	103
Replacing the Lamp	103
Lamp replacement period	103
How to replace the lamp	104
Resetting the lamp hours	106
Replacing the Air Filter	106
Air filter replacement period	106
How to replace the air filter	106

Appendix

Useful Software	109
EasyMP Network Projection(EB-1775W/EB-1770W/EB-1760W only)	109
EasyMP Slide Converter	109
EasyMP Monitor(EB-1775W/EB-1770W/EB-1760W only)	109

Optional Accessories and Consumables	110
Optional Accessories	110
Consumables	110

Monitoring and Controlling (EB-1775W/EB-1770W/EB-1760W Only) 111

Changing Settings Using a Web Browser (Web Control)	111
Projector setup	111
Displaying the Web Control screen	111
Displaying the Web Remote screen	111
Using the Mail Notification Function to Report Problems	113
Reading Error Notification Mail	113
Management Using SNMP	113
ESC/VP21 Commands	114
Before starting	114
Command list	114
Communications protocol	114

About Event ID (EB-1775W/EB-1770W/EB-1760W Only) 116

About PJLink (EB-1775W/EB-1770W/EB-1760W Only) 117

Screen Size and Projection Distance 118

Projection Distance (For EB-1775W/EB-1770W/EB-1760W)	118
Projection Distance (For EB-1750)	119

Supported Monitor Displays 121

Supported Resolutions	121
Computer signals (analog RGB)	121
Component video	121
Composite video	121
Input signal from the HDMI port (EB-1775W/EB-1770W/EB-1760W only)	121

Specifications 123

Projector General Specifications	123
--	-----



Appearance	127
Glossary	128
General Notes	130
About Notations	130
General Notice:	130
Index	147



Introduction

This chapter explains the projector's features and the part names.

List of Functions by Model

Available functions differ depending on the model being used. See the table below for a list of the functions available for each model.

Function	EB-1775W	EB-1770W	EB-1760W	EB-1750
USB Display	✓	✓	✓	✓
HDMI Connection	✓	✓	✓	-
Screen Fit	✓	-	-	-
Auto H/V-Keystone	✓	-	-	-
Auto V-Keystone	-	✓	✓	✓
Wireless LAN Connection	✓	✓*1	✓*1	-
WXGA Resolutions	✓	✓	✓	-
Quick Wireless Connection	✓	✓*2	✓*2	-
Network Menu	✓	✓	✓	-
Slideshow	✓	✓	✓	✓

*1 The Wireless LAN unit is available as an option.

*2 The Quick Wireless Connection USB Key is available as an option.

Quick and Easy Set up, Projection, and Storage

- The portable, lightweight design allows you to easily make presentations away from your office.
- Turn the projector on and off by simply plugging in or unplugging.
- Project onto large screens from a short distance.

- Make easy height adjustments with one lever.
- No cool down delay makes it easy to put away.

Connecting with a USB cable and projecting (USB Display)

By simply connecting the supplied USB cable, you can project images from a computer's screen without a computer cable.

☛ "Projecting with USB Display" p.28

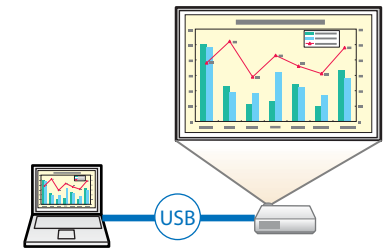

Easy Image Correction

Adjusting the projected image to automatically fit into the screen frame - Screen Fit - (EB-1775W only)

By pressing the [Screen Fit] button, you can automatically adjust the projected image to fit into the screen frame by correcting any image distortion.

☛ "Automatically Adjust to Fit the Screen Frame - Screen Fit - (EB-1775W only)" p.31

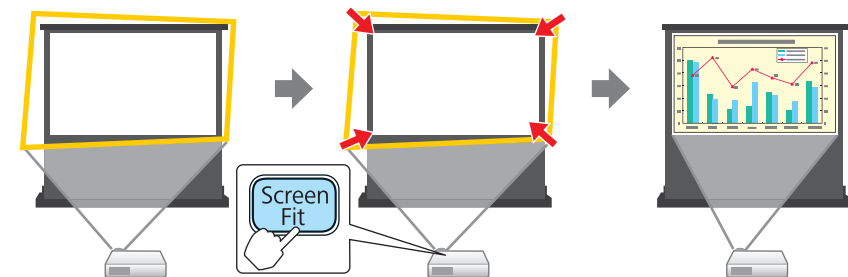

Detecting projector movements and automatically correcting image distortion

This projector automatically corrects keystone distortion and focus problems which occur when positioning or moving the projector.

For EB-1775W

Automatically corrects vertical and horizontal keystone distortion.

☛ "Correcting automatically - Auto H/V-Keystone - (EB-1775W only)" p.33

For EB-1770W/EB-1760W/EB-1750

Automatically corrects vertical keystone distortion.

☛ "Correcting automatically - Auto V-Keystone - (EB-1770W/EB-1760W/EB-1750 only)" p.34

Useful Functions for Expanding the Scope of Your Presentations

Increasing projection content in wide (WXGA) screen (EB-1775W/EB-1770W/EB-1760W only)

By increasing the volume of images and text that you can display, you can improve the impact of your presentation.

☛ "Changing the Aspect Ratio" p.40

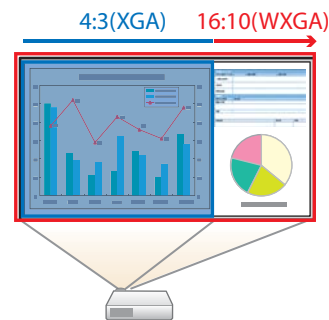

Connecting to a wireless LAN and projecting images from the computer's screen (EB-1775W/EB-1770W/EB-1760W only)

By using EasyMP Network Projection and the supplied or optional Wireless LAN unit, you can wirelessly project the computer's screen.

☛ [EasyMP Network Projection Operation Guide](#)



Connecting a projector and a computer wirelessly with Quick Wireless Connection (EB-1775W/EB-1770W/EB-1760W only)

By simply connecting the supplied or optional Quick Wireless Connection USB Key to a computer, you can connect the projector and the computer using the wireless communication and project images from the computer.

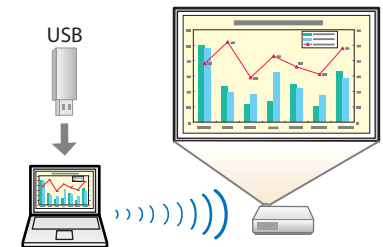

Making the most of the remote control

You can use the remote control to perform operations such as enlarging part of the image. You can also use the remote control as a pointer during presentations or as a mouse for the computer.

☛ "Pointer Function (Pointer)" p.52

☛ "Enlarging Part of the Image (E-Zoom)" p.53

☛ "Using the Remote Control to Operate the Mouse Pointer (Wireless Mouse)" p.54

All of the features in this guide are explained using illustrations of EB-1775W unless otherwise mentioned.

Front/Top

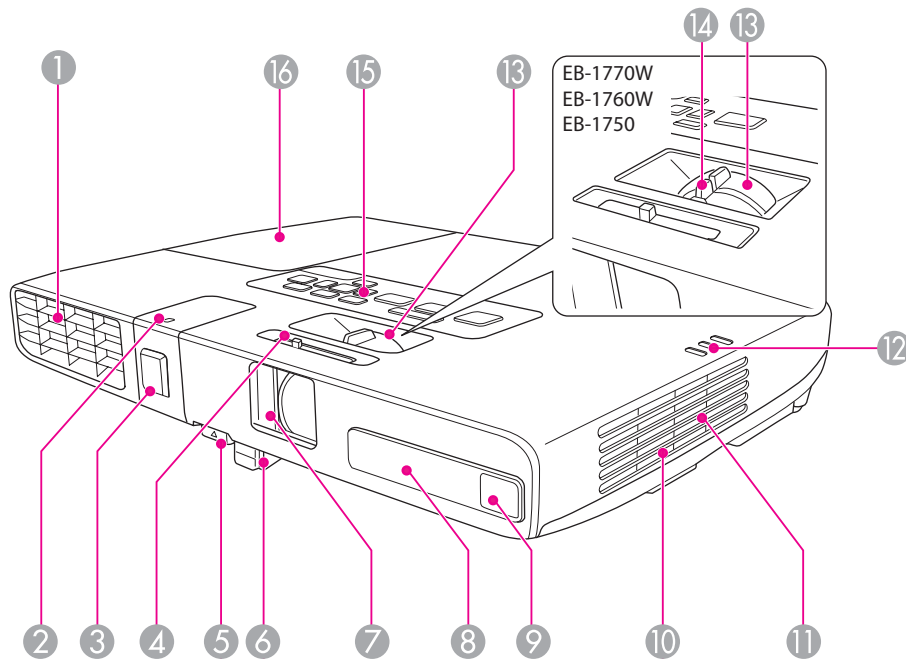

Name	Function
1 Air exhaust vent	Exhaust vent for air used to cool the projector internally. <div style="border: 1px solid black; padding: 5px; background-color: #ffffcc;"> <p>Caution</p> <p>While projecting, do not put your face or hands near the air exhaust vent, and do not place objects that may become warped or damaged by heat near the vent.</p> </div>

Name	Function
2 Wireless LAN indicator (EB-1775W/EB-1770W/ EB-1760W only)	Displays the access status of the supplied or optional Wireless LAN unit.
3 Wireless LAN unit cover (EB-1775W/EB-1770W/ EB-1760W only)	When making a wireless connection between the projector and computer, remove this cover to install the supplied or optional Wireless LAN unit.
4 A/V mute slide knob	Slide the knob to open and close the A/V mute slide.
5 Foot adjust lever	Press the foot lever to extend and retract the front foot. ☛ "Adjusting the Image Position" p.37
6 Front adjustable foot	When setup on a surface such as a desk, extend the foot to adjust the position of the image. ☛ "Adjusting the Image Position" p.37
7 A/V mute slide	Close when not using the projector to protect the lens. By closing during projection you can hide the image and the sound. ☛ "Hiding the Image and Sound Temporarily (A/V Mute)" p.51
8 Remote receiver	Receives signals from the remote control.
9 Sensor (EB-1775W only)	Takes measurements when the projector automatically corrects the projected image.
10 Air intake vent (air filter)	Takes in air to cool the projector internally. ☛ "Cleaning the Air Filter" p.101
11 Speaker	Plays back audio.
12 Indicators	Indicates the projector's status. ☛ "Reading the Indicators" p.88
13 Zoom ring	Adjusts the image size. ☛ "Adjusting the Image Size" p.36
14 Focus ring (EB-1770W/EB-1760W/ EB-1750 only)	Adjusts the image focus. ☛ "Correcting the Focus" p.37

Name	Function
15 Control panel	Operates the projector. ☛ "Control Panel" p.13
16 Lamp cover	Open when replacing the projector's lamp. ☛ "Replacing the Lamp" p.103

Rear

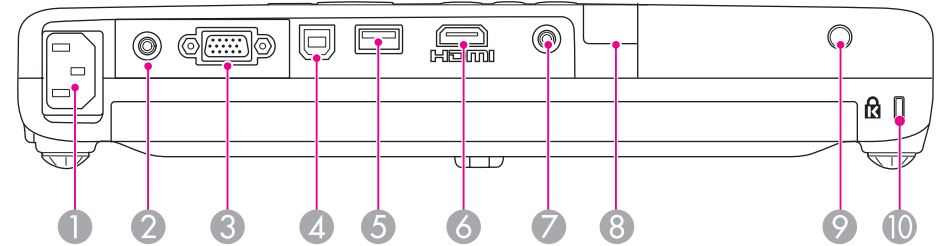

Name	Function
1 Power inlet	Connects the power cable to the projector. ☛ "From Installation to Projection" p.26
2 Video port	Inputs composite video signals from video sources.
3 Computer port	Inputs image signals from a computer and component video signals from other video sources.
4 USB (TypeB) port	<ul style="list-style-type: none"> Connects the projector to a computer via the supplied USB cable, and the image on the computer is projected. ☛ "Projecting with USB Display" p.28 Connects the projector to a computer via the supplied USB cable to use the Wireless Mouse function. ☛ "Using the Remote Control to Operate the Mouse Pointer (Wireless Mouse)" p.54
5 USB (Type A) port	<ul style="list-style-type: none"> Connects a USB memory or digital camera to project data converted by EasyMP Slide Converter (.FSE and .SIT). The data is projected using Slideshow. ☛ "Projecting Without a Computer (Slideshow)" p.45 Connects the optional Document Camera (ELPDC06).
6 HDMI port (EB-1775W/EB-1770W/ EB-1760W only)	Inputs video signals from HDMI compatible video equipment and computers. This projector is compatible with HDCP ▶▶. ☛ "Connecting Equipment" p.21

Name	Function
7 Audio port	Connects an audio cable to output audio from the projector's speakers.
8 Remote receiver	Receives signals from the remote control. ☛ "Remote control operating range" p.17
9 Lamp Cover Fixing Screw	Screw to fix the lamp cover in place.
10 Security slot	The security slot is compatible with the Microsaver Security System manufactured by Kensington. ☛ "Anti-Theft Lock" p.65

Base

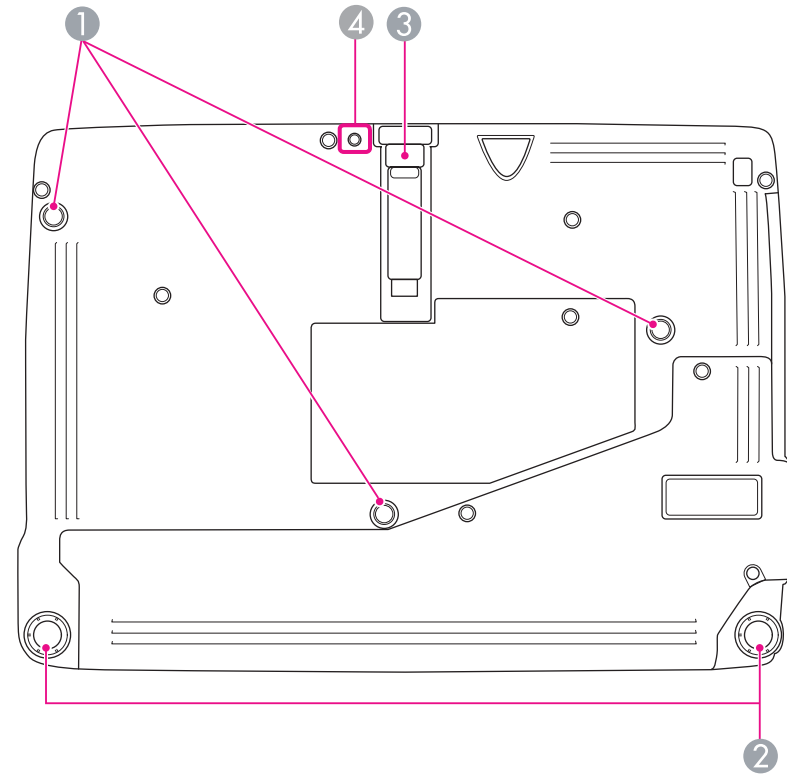

Name	Function
1 Ceiling mount fixing points (three points)	Attach the optional attachment plate here when suspending the projector from a ceiling. ☛ "Installing the Projector" p.19 ☛ "Optional Accessories" p.110
2 Rear feet	When setup on a surface such as a desk, turn to extend and retract to adjust the horizontal tilt. ☛ "Adjusting the Horizontal Tilt" p.37

Name	Function
③ Front adjustable foot	When setup on a surface such as a desk, extend the foot to adjust the position of the image. ☛ "Adjusting the Image Position" p.37
④ Screw hole for the wireless LAN unit cover (EB-1775W/EB-1770W/EB-1760W only)	Screw hole to fix the wireless LAN unit cover.

Control Panel

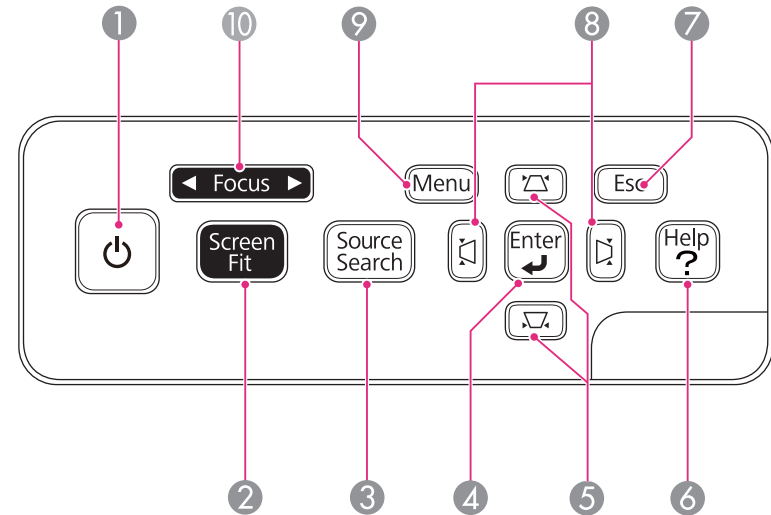

Name	Function
① [Power] button	Turns the projector power on or off. ☛ "From Installation to Projection" p.26
② [Screen Fit] button (EB-1775W only)	Adjusts the projected image so that it fits the screen frame. ☛ "Automatically Adjust to Fit the Screen Frame - Screen Fit - (EB-1775W only)" p.31 This button is disabled when the projector is suspended from a ceiling.
③ [Source Search] button	Changes to the next input source that is sending an image. ☛ "Automatically Detect Input Signals and Change the Projected Image (Source Search)" p.27
④ [Enter] button	<ul style="list-style-type: none"> When the Configuration menu or the Help screen is displayed, it accepts and enters the current selection and moves to the next level. If pressed during projection of computer signal images, it automatically adjusts the Tracking, Sync., and Position to project the optimum image.

Name	Function
5 [△][▽] buttons	<ul style="list-style-type: none"> Performs vertical keystone correction. <ul style="list-style-type: none"> "Correcting keystone distortion in vertical directions" p.34 If pressed when the Configuration menu or the Help screen is displayed, these buttons select menu items and setting values. <ul style="list-style-type: none"> "Using the Configuration Menu" p.67 "Using the Help" p.87
6 [Help] button	<p>Displays and closes the Help screen which shows you how to deal with problems if they occur.</p> <ul style="list-style-type: none"> "Using the Help" p.87
7 [Esc] button	<ul style="list-style-type: none"> Stops the current function. If pressed when the Configuration menu is displayed, it moves to the previous menu level. <ul style="list-style-type: none"> "Using the Configuration Menu" p.67
8 [◀][▶] buttons	<ul style="list-style-type: none"> Performs horizontal keystone correction. <ul style="list-style-type: none"> "Correcting keystone distortion in horizontal directions" p.34 If pressed when the Configuration menu or the Help screen is displayed, these buttons select menu items and setting values. <ul style="list-style-type: none"> "Using the Configuration Menu" p.67 "Using the Help" p.87
9 [Menu] button	<p>Displays and closes the Configuration menu.</p> <ul style="list-style-type: none"> "Using the Configuration Menu" p.67
10 [Focus] button (EB-1775W only)	<p>Adjusts the image focus.</p> <ul style="list-style-type: none"> "Correcting the Focus" p.37

Remote Control

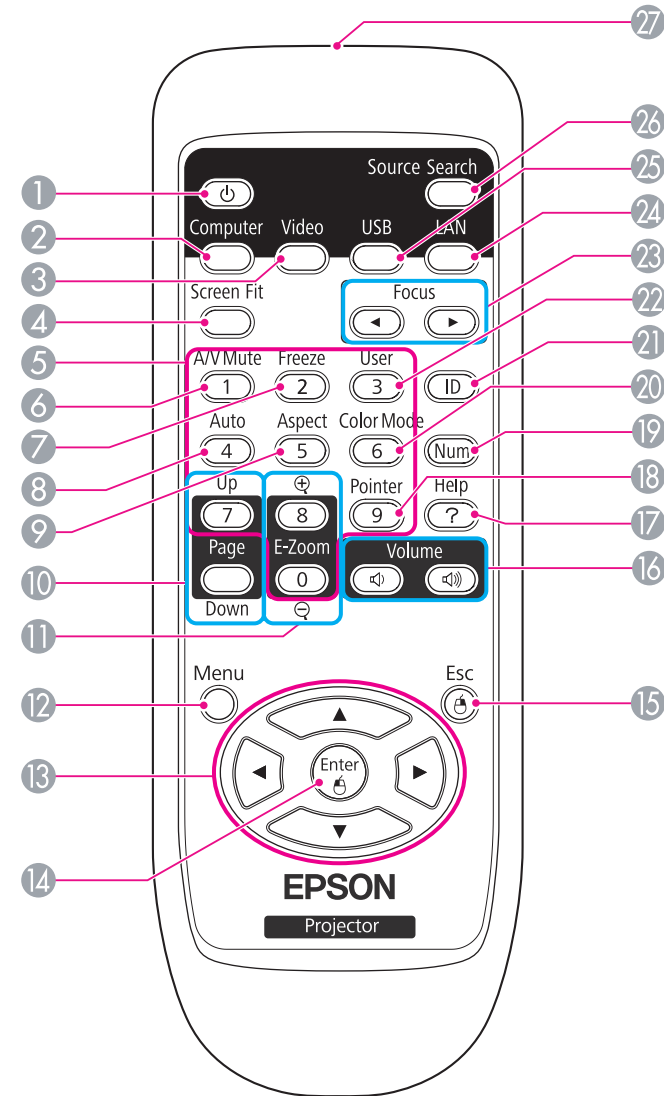

Name	Function
① [⏻] button	Turns the projector power on or off. ☛ "From Installation to Projection" p.26
② [Computer] button	Changes to images from the Computer port.
③ [Video] button	Each time you press the button, the input source changes between images from the Video port and the HDMI port (EB-1775W/EB-1770W/EB-1760W only).
④ [Screen Fit] button	Adjusts the projected image so that it fits the screen frame. (EB-1775W only) ☛ "Automatically Adjust to Fit the Screen Frame - Screen Fit - (EB-1775W only)" p.31 When the projector is suspended from a ceiling or when using EB-1770W/EB-1760W/EB-1750, this does not function even if the button is pressed.
⑤ Numeric buttons	<ul style="list-style-type: none"> Use this button to enter passwords and set the remote control ID. ☛ "Setting the remote control ID" p.57 ☛ "Setting Password Protect" p.62 Use this button to enter numbers in Network settings from the Configuration menu. (EB-1775W/EB-1770W/EB-1760W only)
⑥ [A/V Mute] button	Turns the video and audio on or off. ☛ "Hiding the Image and Sound Temporarily (A/V Mute)" p.51
⑦ [Freeze] button	Images are paused or unpaused. ☛ "Freezing the Image (Freeze)" p.52
⑧ [Auto] button	If pressed during projection of computer signal images, it automatically adjusts the Tracking , Sync. , and Position to project the optimum image.
⑨ [Aspect] button	The aspect ratio changes each time the button is pressed. ☛ "Changing the Aspect Ratio" p.40

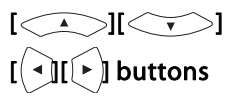
Name	Function
⑩ [Page] buttons [Up] [Down]	Changes pages in files such as PowerPoint files when using the following projection methods. <ul style="list-style-type: none"> When using the Wireless Mouse function ☛ "Using the Remote Control to Operate the Mouse Pointer (Wireless Mouse)" p.54 When using USB Display ☛ "Projecting with USB Display" p.28 During a network connection (EB-1775W/EB-1770W/EB-1760W only) When projecting images or scenarios using Slideshow, pressing these buttons displays the previous/next screen.
⑪ [E-Zoom] buttons [⊕][⊖]	Enlarges or reduces the image without changing the projection size. ☛ "Enlarging Part of the Image (E-Zoom)" p.53
⑫ [Menu] button	Displays and closes the Configuration menu. ☛ "Using the Configuration Menu" p.67
⑬  buttons	<ul style="list-style-type: none"> When the Configuration menu or the Help screen is displayed, pressing these buttons selects menu items and setting values. ☛ "Using the Configuration Menu" p.67 When projecting a Slideshow, pressing these buttons displays the previous/next image, rotates the image, and so on. ☛ "Slideshow operating methods" p.46 During Wireless Mouse function, the mouse pointer moves in the direction of the button that was pushed. ☛ "Using the Remote Control to Operate the Mouse Pointer (Wireless Mouse)" p.54

Name	Function
14 [Enter] button	<ul style="list-style-type: none"> When the Configuration menu or the Help screen is displayed, it accepts and enters the current selection and moves to the next level. <ul style="list-style-type: none"> "Using the Configuration Menu" p.67 Acts as a mouse's left button when using the Wireless Mouse function. <ul style="list-style-type: none"> "Using the Remote Control to Operate the Mouse Pointer (Wireless Mouse)" p.54
15 [Esc] button	<ul style="list-style-type: none"> Stops the current function. If pressed when the Configuration menu is displayed, it moves to the previous level. <ul style="list-style-type: none"> "Using the Configuration Menu" p.67 Acts as a mouse's right button when using the Wireless Mouse function. <ul style="list-style-type: none"> "Using the Remote Control to Operate the Mouse Pointer (Wireless Mouse)" p.54
16 [Volume] buttons [<] [>]	<p>[<] Decreases the volume. [>] Increases the volume.</p> <ul style="list-style-type: none"> "Adjusting the Volume" p.38
17 [Help] button	<p>Displays and closes the Help screen which shows you how to deal with problems if they occur.</p> <ul style="list-style-type: none"> "Using the Help" p.87
18 [Pointer] button	<p>Displays the on-screen pointer.</p> <ul style="list-style-type: none"> "Pointer Function (Pointer)" p.52
19 [Num] button	<p>Hold down this button and press the numeric buttons to enter passwords and numbers.</p> <ul style="list-style-type: none"> "Setting Password Protect" p.62
20 [Color Mode] button	<p>Each time the button is pressed, the Color Mode changes.</p> <ul style="list-style-type: none"> "Selecting the Projection Quality (Selecting Color Mode)" p.38
21 [ID] button	<p>Hold down this button and press the numeric buttons to set the remote control ID.</p> <ul style="list-style-type: none"> "Setting the remote control ID" p.57

Name	Function
22 [User] button	<p>Select any frequently used item from the five available Configuration menu items, and assign it to this button. By pressing the [User] button, the assigned menu item selection/adjustment screen is displayed, allowing you to make one-touch settings/adjustments.</p> <ul style="list-style-type: none"> "Settings Menu" p.73 <p>Power Consumption is assigned as the default setting.</p>
23 [Focus] buttons [←][→]	<p>Adjusts the image focus. (EB-1775W only)</p> <p>When using EB-1770W/EB-1760W/EB-1750, this does not function even if the button is pressed.</p> <ul style="list-style-type: none"> "Correcting the Focus" p.37
24 [LAN] button	<p>Changes to the image projected with EasyMP Network Projection. When projecting using the supplied or optional Quick Wireless Connection USB Key, this button switches to that image. (EB-1775W/EB-1770W/EB-1760W only)</p>
25 [USB] button	<p>Each time the button is pressed, it cycles through the following images:</p> <ul style="list-style-type: none"> USB Display Images from the device connected to the USB (TypeA) port
26 [Source Search] button	<p>Changes to the next input source that is sending an image.</p> <ul style="list-style-type: none"> "Automatically Detect Input Signals and Change the Projected Image (Source Search)" p.27
27 Remote control light-emitting area	<p>Outputs remote control signals.</p>

Replacing the remote control batteries

If delays in the responsiveness of the remote control occur or if it does not operate after it has been used for some time, it probably means that the batteries are becoming flat. When this happens, replace them with new batteries. Have two AA size manganese or alkaline batteries ready. You cannot use other batteries except for the AA size manganese or alkaline.

Attention

Make sure you read the following manual before handling the batteries.

 [Safety Instructions](#)

1 Remove the battery cover.

While pushing the battery compartment cover catch, lift the cover up.

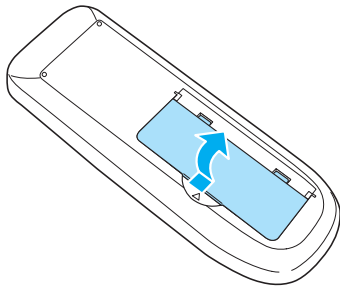

2 Replace the old batteries with new batteries.

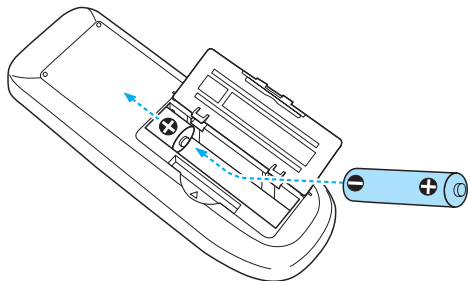

Caution

Check the positions of the (+) and (-) marks inside the battery holder to ensure the batteries are inserted the correct way.

3 Replace the battery cover.

Press the battery compartment cover until it clicks into place.

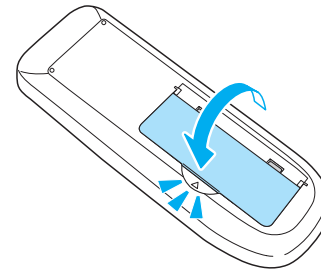

Remote control operating range

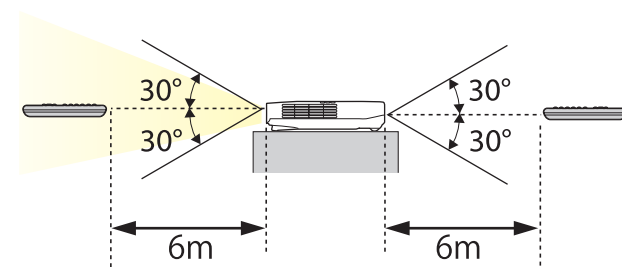
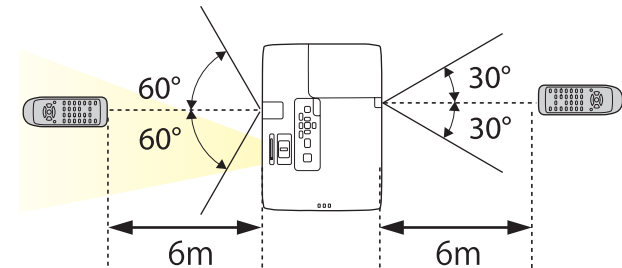



Preparing the Projector

This chapter explains how to install the projector and connect projection sources.

Installation Methods

The projector supports the following four different projection methods. Install the projector according to the conditions of the installation location.

- Project images from in front of the screen. (Front projection)

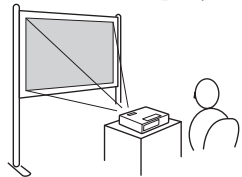

- Project images from behind a translucent screen. (Rear projection)

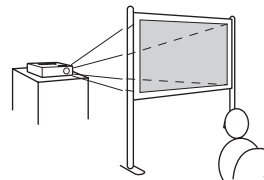

- Suspend the projector from the ceiling and project images from in front of a screen. (Front/Ceiling projection)

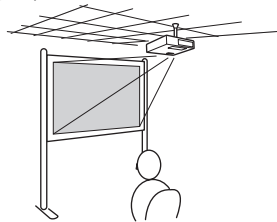

- Suspend the projector from the ceiling and project images from behind a translucent screen. (Rear/Ceiling projection)

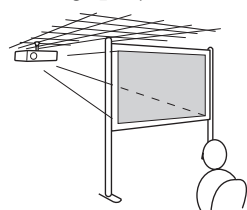

Warning

- A special method of installation is required when suspending the projector from a ceiling (ceiling mount). If it is not installed correctly, it could fall causing an accident and injury.
- If you use adhesives on the Ceiling mount fixing points to prevent the screws from loosening, or if you use things such as lubricants or oils on the projector, the projector case may crack causing it to fall from its ceiling mount. This could cause serious injury to anyone under the ceiling mount and could damage the projector.
When installing or adjusting the ceiling mount, do not use adhesives to prevent the screws from loosening and do not use oils or lubricants and so on.

Attention

- Do not use the projector on its side. This may cause malfunctions to occur.
- Do not cover the projector's air intake vent or air exhaust vent. If either of the vents are covered, the internal temperature could rise and cause a fire.



- An optional ceiling mount and attachment plate are required when suspending the projector from a ceiling.
☛ "Optional Accessories" [p.110](#)
- You can change the setting as follows by pressing down the [A/V Mute] button on the remote control for about five seconds.
Front ↔ Front/Ceiling
Set **Rear** or **Rear/Ceiling** from the Configuration menu.
☛ **Extended - Projection** [p.74](#)

Installation methods

Install the projector so that it is parallel to the screen.

If the projector is installed at an angle to the screen, keystone distortion occurs in the projected image. See the following for more information on correcting keystone distortion.

☛ "Automatically Adjust to Fit the Screen Frame - Screen Fit - (EB-1775W only)" [p.31](#)

☛ "Correcting Keystone Distortion" [p.33](#)

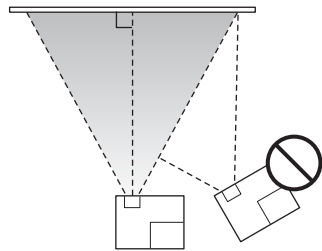

Place the projector on a level surface. See the following if the projected image is tilted horizontally.

☛ "Adjusting the Horizontal Tilt" [p.37](#)

Screen Size and Approximate Projection Distance

Projection size is determined by the distance from the projector to the screen. See the illustrations on the right to select the best position according to the screen size. The illustrations show the approximate shortest distance at maximum zoom. See the following for more information on the projection distance.

☛ "Screen Size and Projection Distance" [p.118](#)



When you correct keystone distortion, the projected image may be reduced.

For EB-1775W/EB-1770W/EB-1760W

16:10 Screen Size

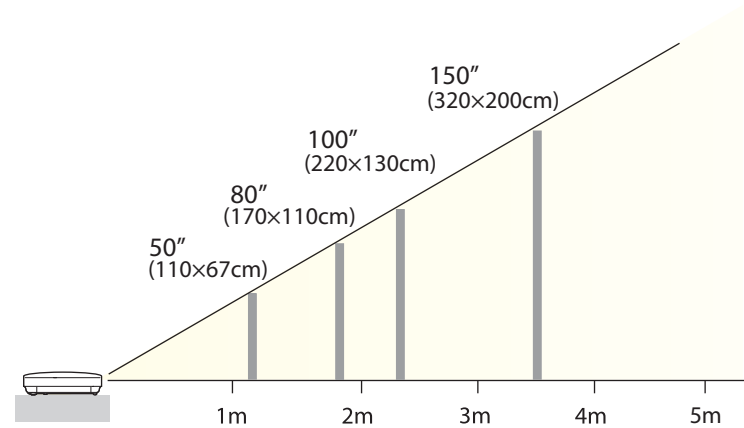

For EB-1750

4:3 Screen Size

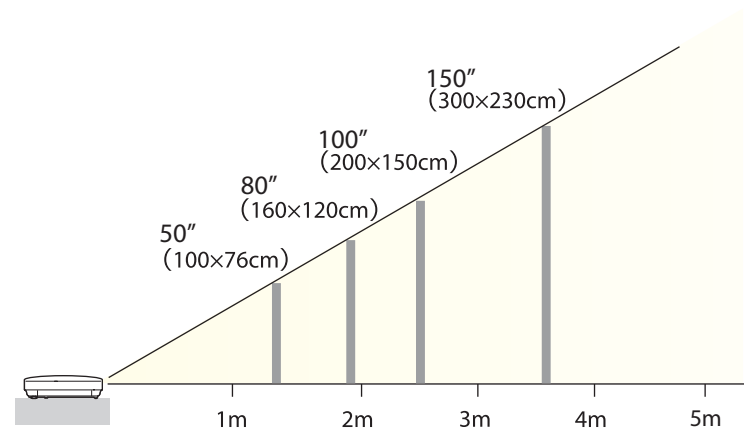

This section gives examples of how to connect the projector and the projection source. Illustrations in this section are of EB-1775W/EB-1770W/EB-1760W. The port name, location, and connector orientation differ depending on the source being connected.

Connecting a Computer

To project images from a computer, connect the computer using one of the following methods.

- ① **When using the supplied computer cable**
Connect the computer's display output port to the projector's Computer input port using the supplied computer cable. To output audio from the projector's speaker, you need to connect a commercially available audio cable.
- ② **When using the supplied USB cable**
Connect the computer's USB port to the projector's USB (Type B) port using the supplied USB cable.
- ③ **When using a commercially available HDMI cable**
Connect the computer's HDMI port to the projector's HDMI port using a commercially available HDMI cable.

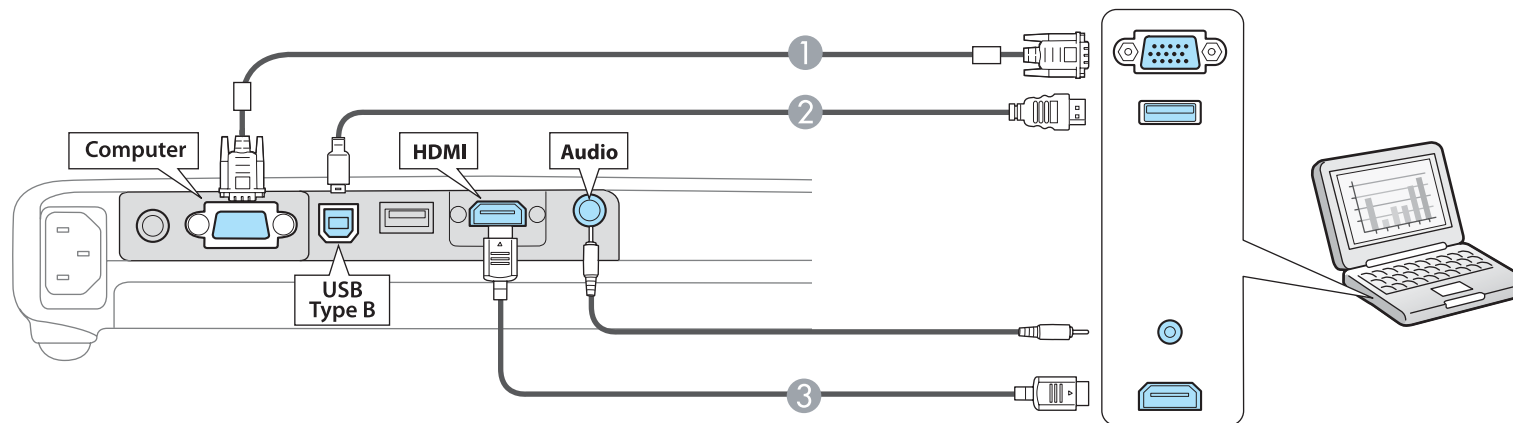

Simply by connecting the projector to a computer via a USB cable, you can project images from the computer. This function is called USB Display.

☛ "Projecting with USB Display" [p.28](#)

Connecting Image Sources

To project images from DVD players or VHS video and so on, connect to the projector using one of the following methods.

1 When using a commercially available video cable

Connect the video output port on the image source to the projector's Video input port using a commercially available video cable. To output audio from the projector's speaker, you need to connect a commercially available audio cable.

2 When using the optional component video cable

☞ "Optional Accessories" p.110

Connect the component output port on the image source to the projector's Computer input port using the optional component video cable. To output audio from the projector's speaker, you need to connect a commercially available audio cable.

3 When using a commercially available HDMI cable

Connect the HDMI port on the image source to the projector's HDMI port using a commercially available HDMI cable.

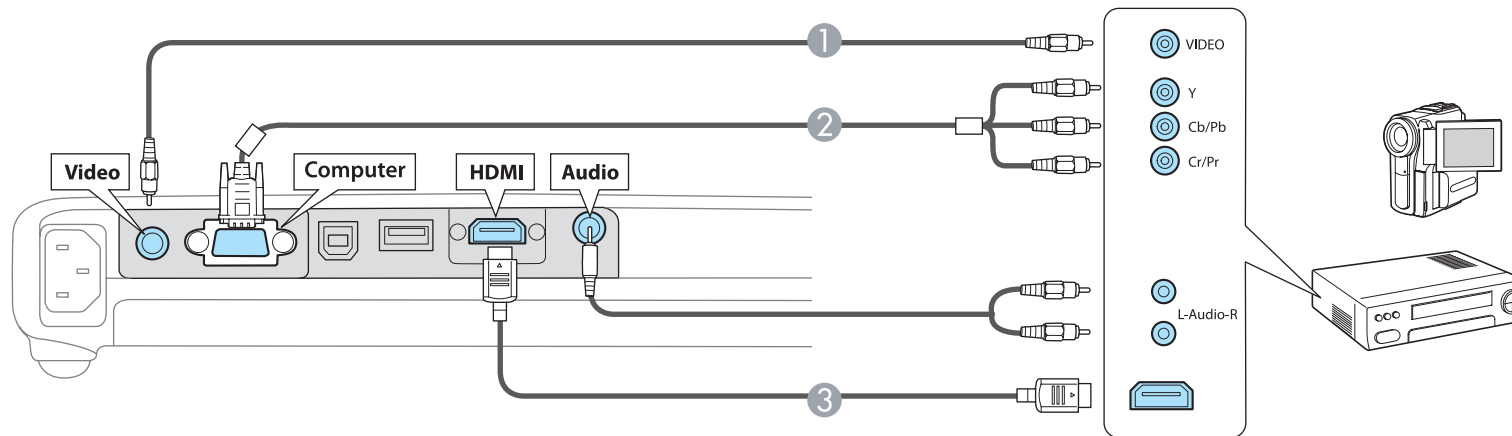

Attention

- If the input source is on when you connect it to the projector, it could cause a malfunction.
- If the orientation or shape of the plug differs, do not try to force it in. The device could be damaged or could malfunction.



- If the source you want to connect to has an unusually shaped port, use the cable supplied with the device or an optional cable to connect to the projector.
- When using a commercially available 2RCA(L/R)/stereo mini-pin audio cable, make sure it is labeled "No resistance".

Connecting USB Devices

You can connect devices such as USB memory, the optional Document Camera, and USB compatible hard disks and digital cameras.

Using the USB cable supplied with the USB device, connect the USB device to the USB (Type A) port on the projector.

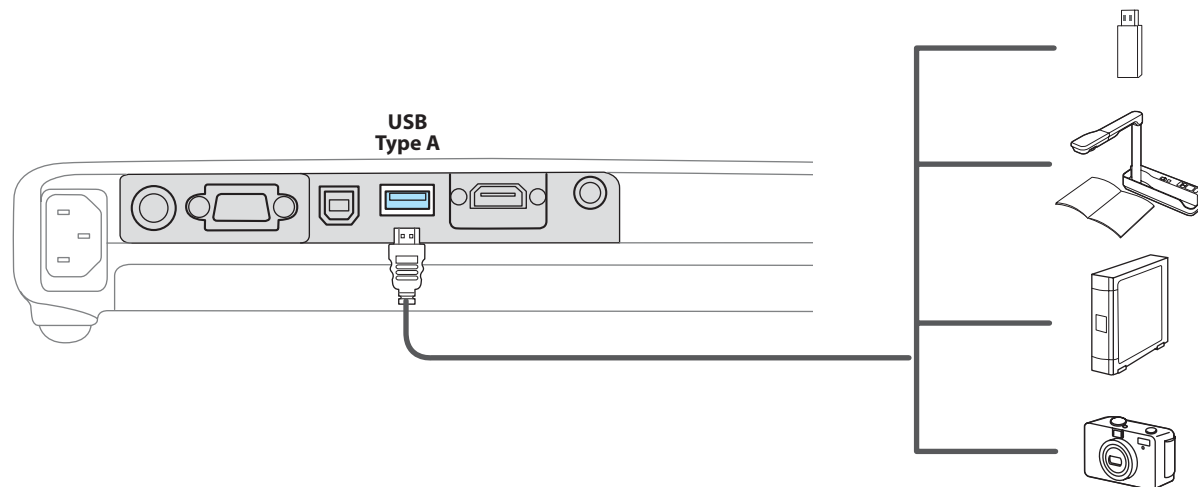

When the USB device is connected, you can project image files on the USB memory or digital camera using Slideshow.

☛ "Slideshow examples" [p.45](#)

If the Document Camera is connected while another image source is projecting, press the [USB] button on the remote control, or the [Source Search] button on the control panel to switch to images from the Document Camera.

☛ "Automatically Detect Input Signals and Change the Projected Image (Source Search)" [p.27](#)

Attention

- If you use a USB hub, the connection may not operate correctly. Devices such as digital cameras and USB devices should be connected to the projector directly.
- When connecting and using a USB-compatible hard disk, make sure you connect the AC adaptor supplied with the hard disk.
- Connect a digital camera or hard disk to the projector using a USB cable supplied with or specified for use with the device.
- Use a USB cable less than 3 m in length. If the cable exceeds 3 m, Slideshow may not function correctly.



Removing USB devices

After finishing projecting, remove USB devices from the projector. For devices such as digital cameras or hard disks, turn off the device and then remove it from the projector.





Basic Usage

This chapter explains how to project and adjust images.

From Installation to Projection

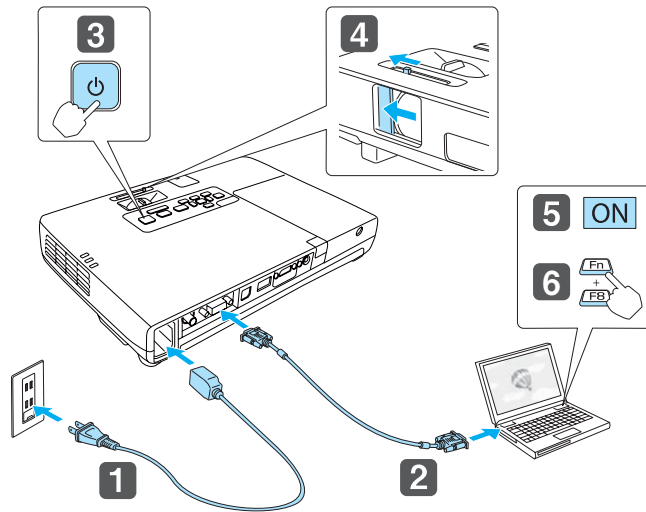
This section explains the procedure for connecting the projector to a computer with the computer cable and projecting images.



- 1** Connect the projector to an electrical outlet with the power cable.
- 2** Connect the projector to the computer with the computer cable.
- 3** Turn on the projector.
- 4** Slide open the A/V mute slide.
- 5** Turn on your computer.
- 6** Change the computer's screen output.
When using a laptop computer, you need to change the screen output from the computer.
Hold down the Fn key (function key), and press the /□ key.



The method for changing differs depending on the computer being used. See the documentation supplied with the computer.

If the image is not projected, you can change the projected image using one of the following methods.

- Press the [Source Search] button on the control panel or the remote control.
 - ☛ "Automatically Detect Input Signals and Change the Projected Image (Source Search)" [p.27](#)
- Press the button for the target port on the remote control.
 - ☛ "Switching to the Target Image by Remote Control" [p.28](#)



After projecting the image, adjust the image if necessary.

- ☛ "Automatically Adjust to Fit the Screen Frame - Screen Fit - (EB-1775W only)" [p.31](#)
- ☛ "Correcting Keystone Distortion" [p.33](#)
- ☛ "Correcting the Focus" [p.37](#)

Automatically Detect Input Signals and Change the Projected Image (Source Search)

Press the [Source Search] button to project images from the port currently receiving an image.

Because only images from ports receiving an image are projected, you can quickly project the image you want.

Using the remote control

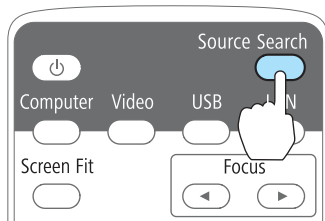

Using the control panel

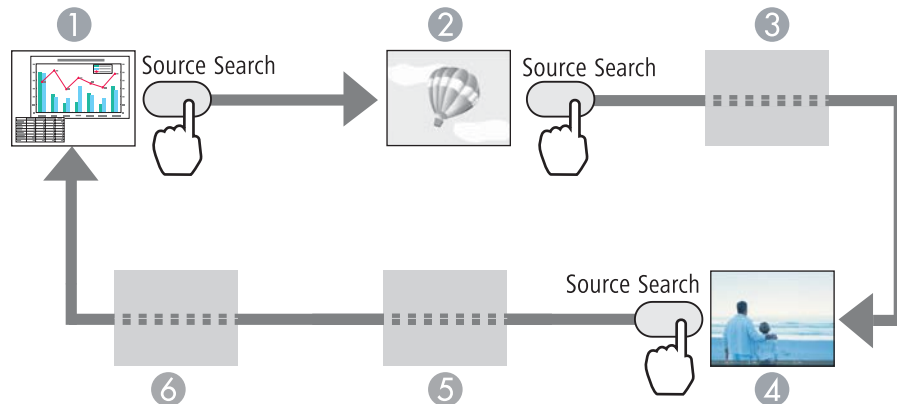
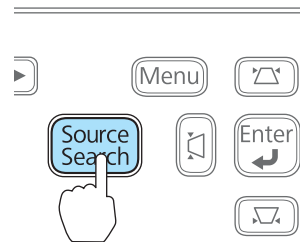

- ① Computer
- ② Video
- ③ HDMI (EB-1775W/EB-1770W/EB-1760W only)
- ④ USB Display
- ⑤ USB
- ⑥ LAN

⑥ LAN (EB-1775W/EB-1770W/EB-1760W only)

When two or more image sources are connected, press the [Source Search] button until the target image is projected.

When your video equipment is connected, start playback before beginning this operation.



The following screen is displayed when only the image that the projector is currently displaying is available, or when no image signal can be found. You can select the port where the equipment you want to use is connected. If no operation is performed after about 10 seconds, the screen closes.

Example: EB-1775W/EB-1770W/EB-1760W

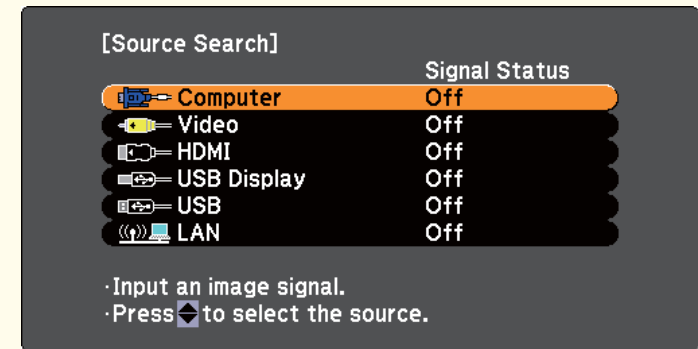

[] : Select [Enter] : Enter [Esc] : Exit

Switching to the Target Image by Remote Control

You can change directly to the target image by pressing the following buttons on the remote control.

Remote control

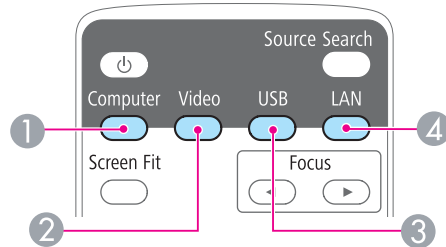

- ① Changes to images from the Computer port.
- ② Each time the button is pressed, it cycles through the following images:
 - Video port
 - HDMI port (EB-1775W/EB-1770W/EB-1760W only)
- ③ Each time the button is pressed, it cycles through the following images:
 - USB Display
 - Images from the device connected to the USB (TypeA) port
- ④ Changes to the image projected with EasyMP Network Projection. When projecting using the supplied or optional Quick Wireless Connection USB Key, this button switches to that image. (EB-1775W/EB-1770W/EB-1760W only)

Projecting with USB Display

You can use the supplied USB cable to connect the projector to a computer to project images from the computer.

To start USB Display, set **USB Type B** to **USB Display** from the Configuration menu.

☛ **Extended - USB Type B p.74**

System Requirements

For Windows

OS	Windows 2000 Service Pack 4 The following 32 bit operating systems: Windows XP Windows XP Service Pack 2 or later Windows Vista Windows Vista Service Pack 1 or later Windows 7
CPU	Mobile Pentium III 1.2 GHz or faster Recommended: Pentium M 1.6 GHz or faster
Amount of Memory	256 MB or more Recommended: 512 MB or more
Hard Disk Free space	20 MB or more
Display	Resolution of no less than 640x480 and no higher than 1600x1200. Display color in 16-bit color or greater

For Mac OS

OS	Mac OS X 10.5.1 or later Mac OS X 10.6.x
CPU	Power PC G4 1GHz or faster Recommended: Core Duo 1.83GHz or faster
Amount of Memory	512 MB or more
Hard Disk Free Space	20 MB or more
Display	Resolution of no less than 640x480 and no higher than 1680x1200. Display color in 16-bit color or greater

Connecting for the first time

The first time you connect the projector and the computer using the USB cable, the driver needs to be installed. The procedure is different for Windows and Mac OS.



- You do not need to install the driver the next time you connect.
- When inputting images from multiple sources, change the input source to USB Display.

For Windows

- 1** Driver installation starts automatically.
When you are using Windows 2000, double-click **Computer - EPSON_PJ_UD - EMP_UDSE.EXE** on your computer.
- 2** When the License Agreement screen is displayed, click **Agree**.
- 3** Computer images are projected.
It may take a while before computer images are projected. Until computer images are projected, leave the equipment as it is and do not disconnect the USB cable or turn off the power to the projector.
- 4** Disconnect the USB cable when you are finished.
When disconnecting the USB cable, there is no need to use **Safely Remove Hardware**.



- If it is not installed automatically, double-click **My Computer** - **EPSON_PJ_UD** - **EMP_UDSE.EXE** on your computer.
- If nothing is projected for some reason, click **All Programs** - **EPSON Projector** - **EPSON USB Display** - **EPSON USB Display Vx.xx** on your computer.
- When using a computer running Windows 2000 under user authority, a Windows error message is displayed and you may not be able to use the software. In this case, try updating Windows to the latest version, restart, and then try to connect again.

For more details, contact your local dealer or the nearest address provided in the following document.

 [Epson Projector Contact List](#)



- If the USB Display setup folder is not displayed automatically in the Finder, double-click **EPSON PJ_UD** - **USB Display Installer** on your computer.
- If nothing is projected for some reason, click the **USB Display** icon in the Dock.
- If there is no **USB Display** icon in the Dock, start **USB Display** from the Applications folder.
- If you select **Exit** from the **USB Display** icon menu on the Dock, USB Display does not start automatically when you connect the USB cable.

For Mac OS

- 1** The Setup folder of USB Display is displayed in the Finder.
- 2** Double-click the **USB Display Installer** icon.
- 3** Follow the on-screen instructions to install.
- 4** When the License Agreement screen is displayed, click **Agree**.
Enter the administrator authority password and start the installation.
When the installation is complete, the USB Display icon is displayed in the Dock and menu bar.
- 5** Computer images are projected.
It may take a while before computer images are projected. Until computer images are projected, leave the equipment as it is and do not disconnect the USB cable or turn off the power to the projector.
- 6** Select **Disconnect** from the **USB Display** icon menu on the menu bar or Dock, and then remove the USB cable.

Uninstalling

For Windows

Click **Control Panel** - **Add/Remove Programs** and uninstall **EPSON USB Display**.

For Mac OS

Double-click **Applications** and then **USB Display**. Start **USB Display UnInstaller** in the **Tool** folder.

Automatically Adjust to Fit the Screen Frame - Screen Fit - (EB-1775W only)

Screen Fit is a function that corrects the projected image so that it aligns with the frame (outer border) of the screen, white board, and so on. By pressing the [Screen Fit] button on the remote control or the control panel, the projected image is adjusted to fit the screen, and keystone correction and focus adjustments are performed automatically.

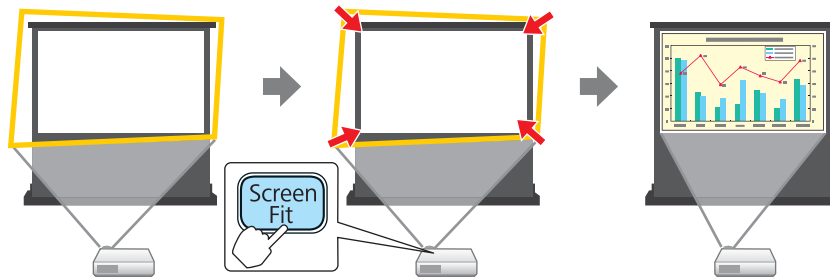

The following conditions are necessary to correct the projected image using Screen Fit.

Screen size: less than or equal to 100"

Distance between projector and screen: approx. 1.0 to 2.5 m

Correction angle: approx 20° right and left/approx. 30° up and down

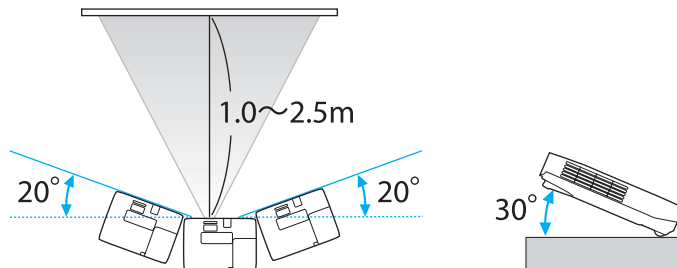

- If you exceed the above mentioned range, the projected image cannot be corrected properly. Correct the projected image manually.
- Screen Fit does not function if the projector is suspended from a ceiling. Correct the projected image manually.

- 1 Press the [Screen Fit] button on the remote control or the control panel during projection.

Using the remote control

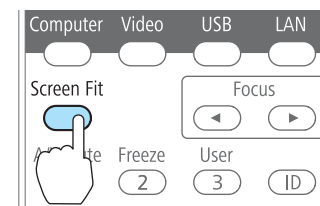

Using the control panel

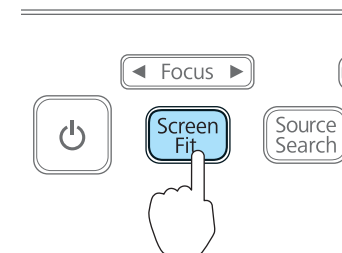

- Adjust the zoom ring so that the yellow frame is bigger than the screen frame as shown below. Position the black message box in the center of the screen.

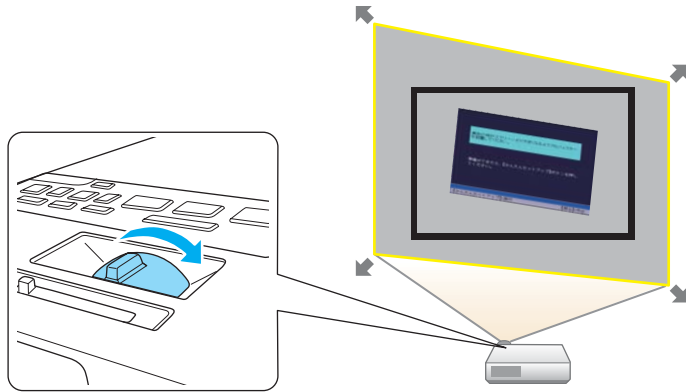

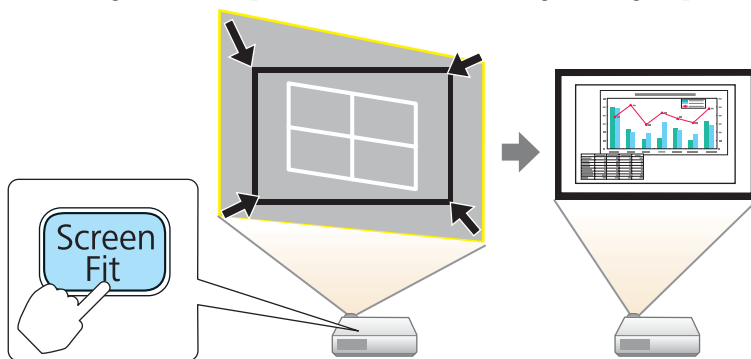

If the yellow frame is still within the screen frame even after adjusting the zoom ring to its maximum size, try moving the projector further away from the screen.

- Press the [Screen Fit] button or the [Enter] button. After the adjustment screen appears, the projected image is corrected according to the aspect ratio of the image being input.



Once the adjustment screen appears, do not move the projector or block the image. The projected image will not be corrected properly.

- After the correction is performed, the following message appears. To exit the correction menu, press the [Esc] button on the remote control or the control panel to clear the message. To fine-tune the projected image after it has been corrected, make the adjustments using the  buttons on the control panel.

The revision result can be adjusted by  on the main control panel.

If no operation is performed, the message closes after about 7 seconds.

After executing Screen Fit, **Keystone** from the Configuration menu is set to **Quick Corner**. After this, any correction of the projected image using the  buttons on the control panel is performed using the Quick Corner function.

☛ "Correcting manually - Quick Corner -" [p.34](#)



- Screen Fit corrects the projected image when it detects two or more sides inside the projected area, and aligns with the detected frame. For example, when projecting onto a wide screen in a small room, you can make corrections by fitting the top and bottom sides of the screen into the projected area.

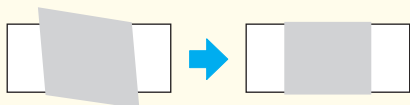

- Screen Fit may not work well in dark environments, such as a room with lights turned off. In this case, make the room brighter, and then try executing Screen Fit again.
- Because Screen Fit uses a sensor, it may not work properly depending on the condition of the projection surface (deflections, patterns, and so on) or the effects of outside light. In this case, make the adjustments manually.

☞ "Correcting manually - manual H/V-Keystone -" p.34

- Correcting manually (manual H/V-Keystone)
Manually correct distortion in the horizontal and vertical directions independently.

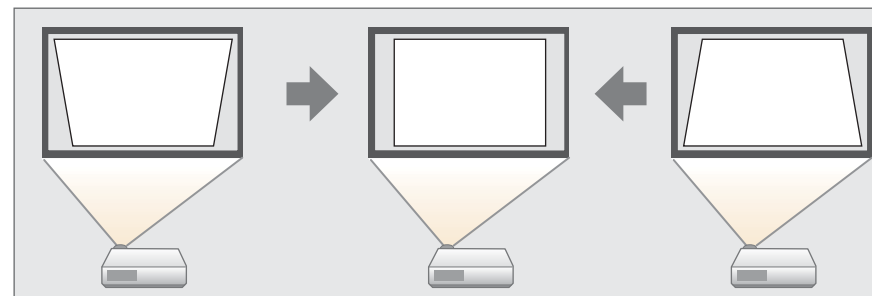

- Correcting manually (Quick Corner)
Manually correct the four corners independently.

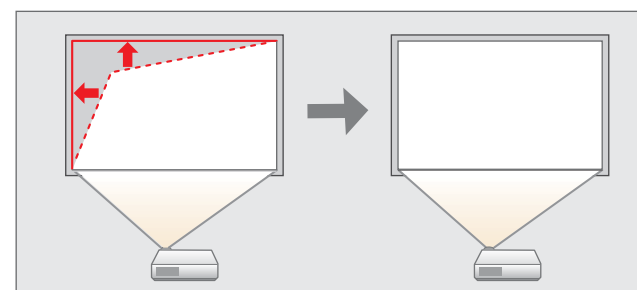

When you correct keystone distortion, the projected image may be reduced.

Correcting Keystone Distortion

You can correct keystone distortion using one of the following methods.

- Correcting automatically
Automatically correct keystone distortion.
-Auto H/V-Keystone (EB-1775W only)
-Auto V-Keystone (EB-1770W/EB-1760W/EB-1750 only)

Correcting automatically - Auto H/V-Keystone - (EB-1775W only)

When the projector detects any movement, for example when it is installed, moved, repositioned, or tilted, it automatically corrects vertical and horizontal keystone distortion. This function is called Auto H/V-Keystone.

When the projector remains still for about two seconds after it detects movement, it displays a screen for adjustment and then automatically corrects the projected image.

- Auto H/V-Keystone only works when **Projection** is set to **Front** from the Configuration menu.
 🖱️ **Extended - Projection** p.74
- If you do not want to use the Auto H/V-Keystone function, set **Auto H/V-Keystone** to **Off**.
 🖱️ **Settings - Keystone - H/V-Keystone - Auto H/V-Keystone** p.73

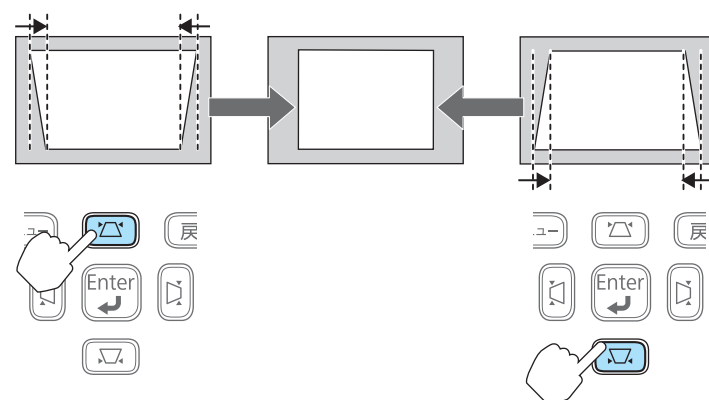

Correcting keystone distortion in horizontal directions

Press the   buttons on the control panel.

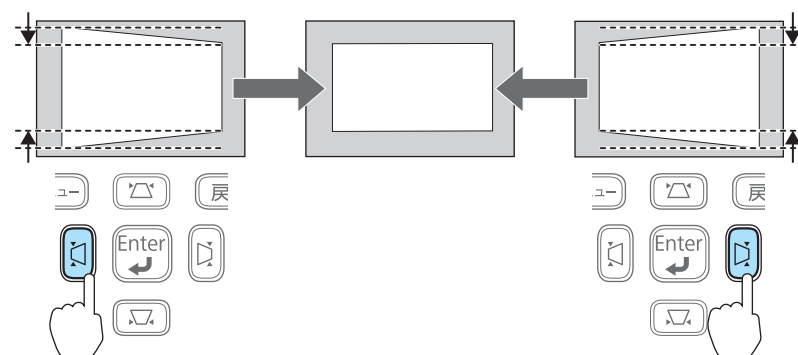

Correcting manually - manual H/V-Keystone -

Manually correct distortion in the horizontal and vertical directions independently. H/V-Keystone correction is ideal for fine-tuning keystone distortion.

Correcting keystone distortion in vertical directions

Press the   buttons on the control panel.

- You can set manual H/V-Keystone from the Configuration menu.
 🖱️ **Settings - Keystone - H/V-Keystone** p.73

Correcting manually - Quick Corner -

This allows you to manually correct each of the four corners of the projected image separately.

1 Press the [Menu] button while projecting.

☛ "Using the Configuration Menu" p.67

Using the remote control

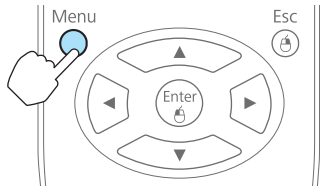

Using the control panel

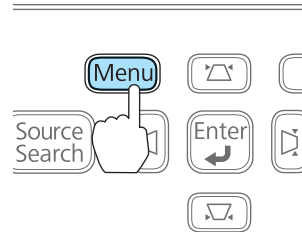

2 Select **Keystone** from **Settings**.

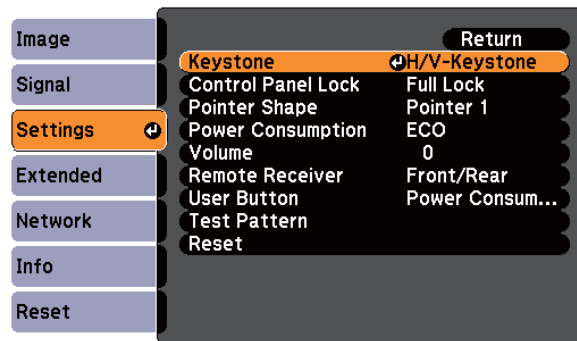

[Esc]:Return [↕]:Select [Enter]:Enter [Menu]:Exit

3 Select **Quick Corner**, and then press the [Enter] button.

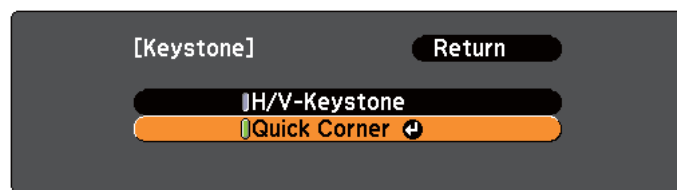

[Esc]:Return [↕]:Select [Enter]:Enter [Menu]:Exit

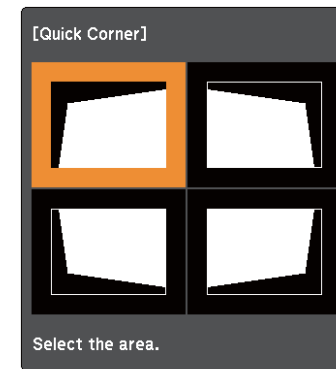

[↕/↔]:Select
[Enter]:Enter
[Esc]:Return (press for 2 seconds to reset/switch)

4 Using the [↕], [↔], [↶], and [↷] buttons on the remote control, or the [↕], [↔], [↶], and [↷] buttons on the control panel, select the corner to correct, and then press the [Enter] button.

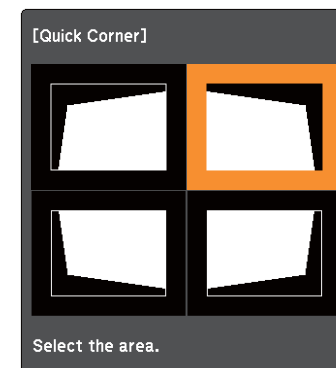

5 Using the [↖], [↘], [←], and [→] buttons on the remote control, or the [↖], [↘], [←], and [→] buttons on the control panel, correct the position of the corner.

If the triangle in the direction you are adjusting the shape turns gray, as shown in the screenshot below, you cannot adjust the shape any further in that direction.

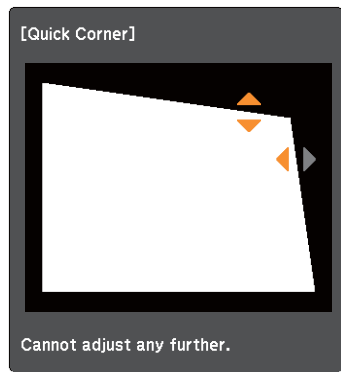

6 Repeat procedures 4 and 5 as needed to adjust any remaining corners.

7 When you are done, press the [Esc] button to exit the correction menu.

Because **Keystone** was changed to **Quick Corner**, the corner selection screen from step 3 is displayed when you press the [↖], [↘], [←], and [→] buttons on the control panel next time. Change **Keystone** to **H/V-Keystone** if you want to perform horizontal and vertical correction using the [↖], [↘], [←], and [→] buttons on the control panel.

☛ **Settings - Keystone - H/V-Keystone p.73**



- When **Auto H/V-Keystone** is set to **On**, the message "Do you want to perform Auto H/V-Keystone correction?" is displayed when the projector is moved. (EB-1775W only)

After you perform this function, the **Keystone** setting changes from **Quick Corner** to **H/V-Keystone**, after which pressing the [↖], [↘], [←], and [→] buttons on the control panel performs H/V-Keystone.

☛ **Settings - Keystone - H/V-Keystone p.73**

- If the [Esc] button is held down for about two seconds while correcting with Quick Corner, the following screen is displayed.

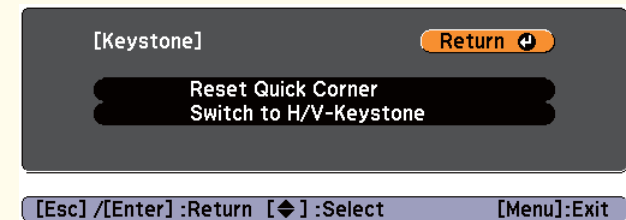

Reset Quick Corner: Resets the result of Quick Corner corrections.

Switch to H/V-Keystone: Switches the correction method to H/V-Keystone.

☛ "Settings Menu" p.73

Adjusting the Image Size

Turn the zoom ring to adjust the size of the projected image.

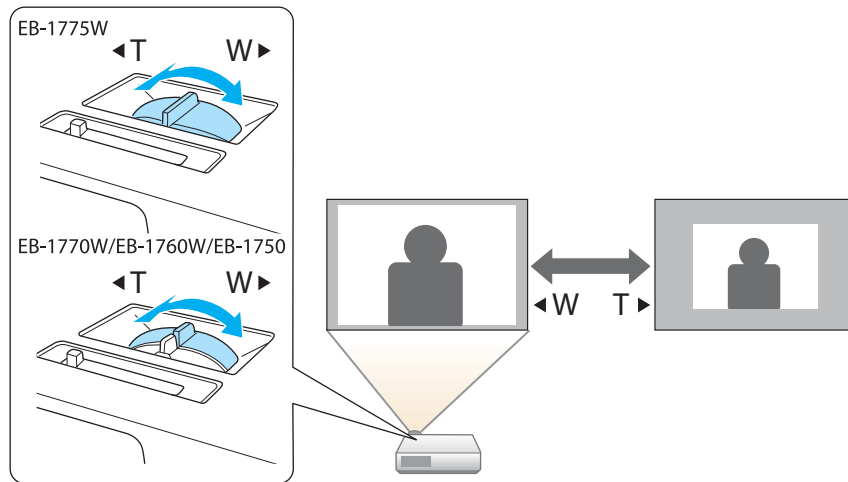

Adjusting the Image Position

Press the foot lever to extend and retract the front foot. You can adjust the position of the image by tilting the projector up to 14 degrees.

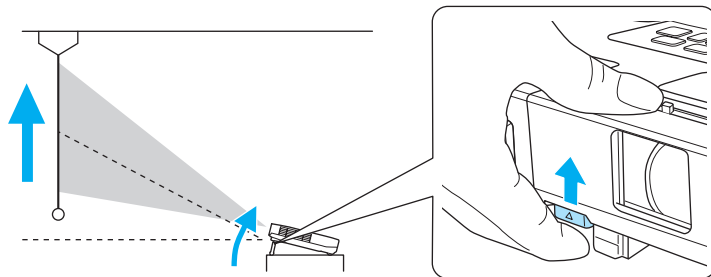

The larger the angle of tilt, the harder it becomes to focus. Install the projector so that it only needs to be tilted at a small angle.

Adjusting the Horizontal Tilt

Extend and retract the rear feet to adjust the projector's horizontal tilt.

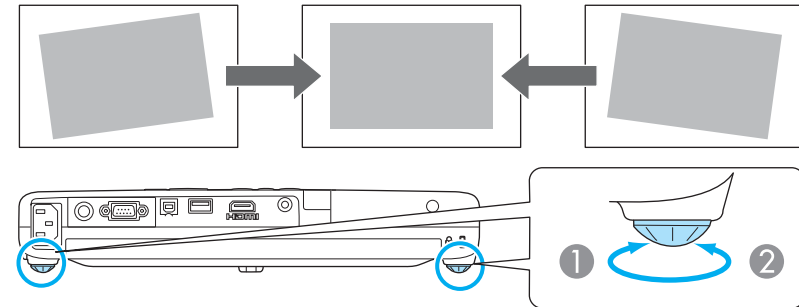

- 1 Extend the rear foot.
- 2 Retract the rear foot.

Correcting the Focus

You can correct the focus using one of the following methods.

- Press the [Focus] button on the control panel or the remote control to adjust the focus. (EB-1775W only)

- Turn the focus ring to adjust the focus. (EB-1770W/EB-1760W/EB-1750 only)

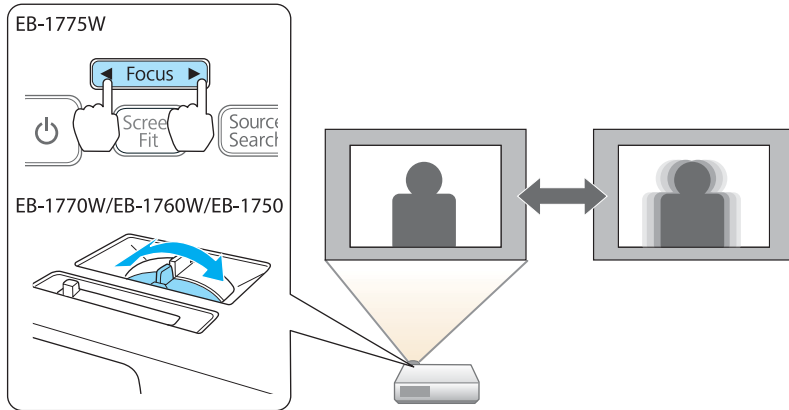

- Adjust the volume from the Configuration menu.
 ⚙️ **Settings - Volume** p.73

⚠️ Caution

Do not start at high volume.
 A sudden excessive volume may cause loss of hearing. Always lower the volume before powering off, so that you can power on and then gradually increase the volume.

Adjusting the Volume

You can adjust the volume using one of the following methods.

- Press the [Volume] buttons on the remote control to adjust the volume.

Remote control

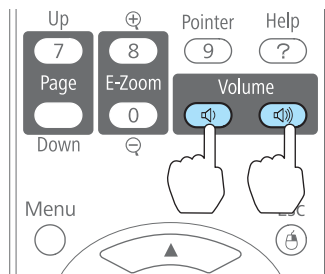

[🔊] Decreases the volume.

[🔊] Increases the volume.

Selecting the Projection Quality (Selecting Color Mode)

You can easily obtain the optimum image quality simply by selecting the setting that best corresponds to your surroundings when projecting. The brightness of the image varies depending on the mode selected.

Mode	Application
Dynamic	Ideal for use in a bright room. This is the brightest mode, and reproduces shadow tones well.
Presentation	Ideal for making presentations using color materials in a bright room.
Theatre	Ideal for watching films in a dark room. Gives images a natural tone.
Photo*1	Ideal for projecting still pictures, such as photos, in a bright room. The images are vivid and brought into contrast.
Sports*2	Ideal for watching TV programmes in a bright room. The images are vivid and brought to life.
sRGB	Ideal for images that conform to the <u>sRGB</u> color standard.

Mode	Application
Blackboard	Even if you are projecting onto a blackboard (greenboard), this setting gives your images a natural tint, just like when projecting onto a screen.
Whiteboard	Ideal for making presentations using a whiteboard.
Customized	Select Customized if you want to adjust the R, G, B, C, M, and Y settings in the Color Adjustment submenu of the Configuration menu.

*1 This selection is only available when the input signal is RGB or when the source is USB Display, USB, or LAN. (Depending on the model used, some sources are not supported.)

*2 This selection is only available when the input signal is component video, or when the source is Video.

Each time you press the [Color Mode] button, the Color Mode name is displayed on the screen and the Color Mode changes.

Remote control

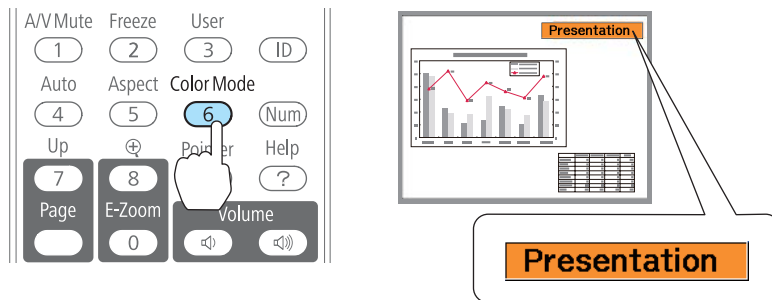

You can set Color Mode from the Configuration menu.

🖱️ **Image - Color Mode** p.70

Setting Auto Iris

By automatically setting the luminance according to the brightness of the displayed image, it lets you enjoy deep and rich images.

1 Press the [Menu] button.

🖱️ "Using the Configuration Menu" p.67

Using the remote control

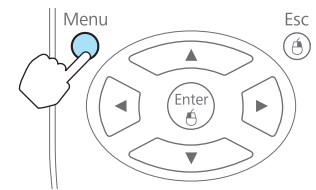

Using the control panel

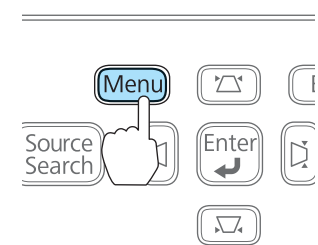

2 Select **Auto Iris** from **Image**.

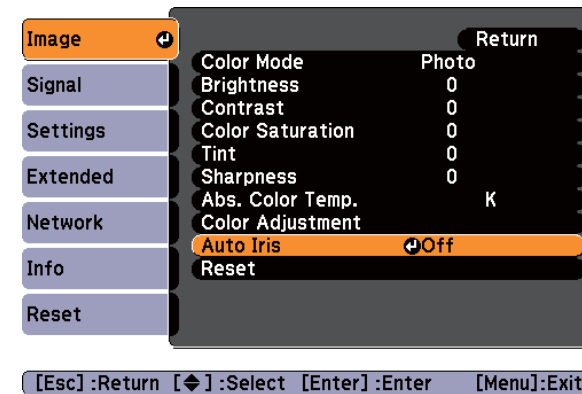

3 Select **On**.

The setting is stored for each Color Mode.

4 Press the [Menu] button to finish making settings.



Auto Iris can be set only when the **Color Mode** is **Dynamic**, **Theatre**, or **Customized**.

Changing the Aspect Ratio

Change the **aspect ratio** when video equipment is connected so that images that have been recorded in digital video or onto DVDs can be viewed in 16:9 wide-screen format. Change the aspect ratio when projecting computer images at full size.

Available Aspect Modes vary depending on the image signal currently being projected.

The changing methods and the types of Aspect Modes are as follows.

Changing methods

Each time you press the [Aspect] button, the Aspect Mode name is displayed on the screen and the aspect ratio changes.

Remote control

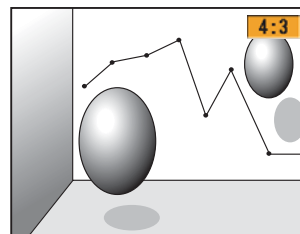
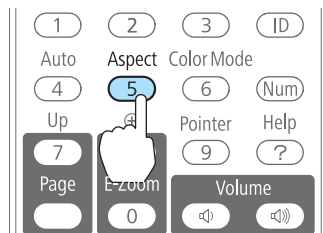

You can set the aspect ratio from the Configuration menu.

➔ **Signal - Aspect p.71**

Changing the aspect ratio for video equipment images

For EB-1775W/EB-1770W/EB-1760W

Each time the button is pressed, the aspect ratio changes in the order of **Normal** or **Auto**, **16:9**, **Full**, **Zoom**, and **Native**.

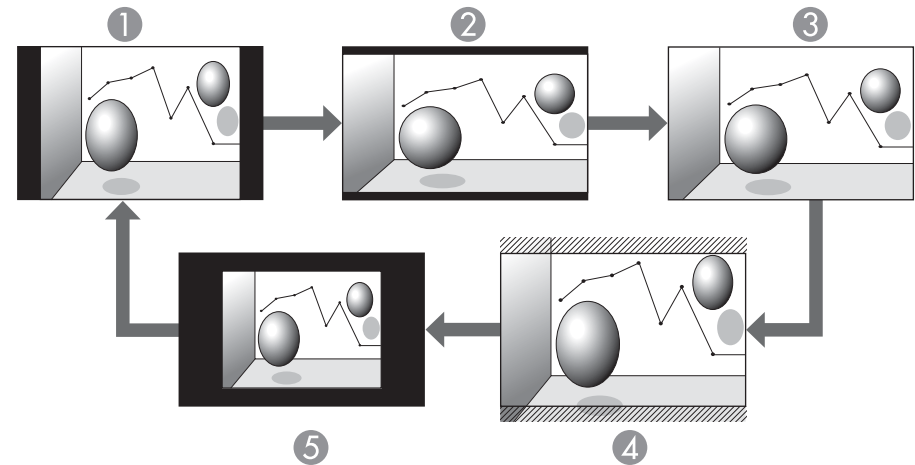

- ① Normal or Auto
- ② 16:9
- ③ Full
- ④ Zoom
- ⑤ Native

For EB-1750

Each time the button is pressed, the aspect ratio changes in the order of **Normal**, **4:3**, and **16:9**.

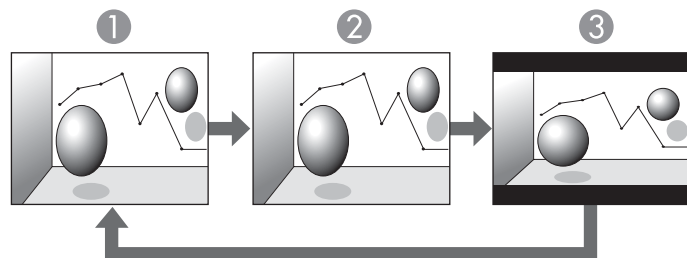

- ① Normal
- ② 4:3
- ③ 16:9

* When a 720p/1080i signal is input, the display is in a zoomed 4:3 format (the image is cut off on the right and left sides).

Changing the aspect ratio for computer images

For EB-1775W/EB-1770W/EB-1760W

Each time the button is pressed, the aspect ratio changes in the order of **Normal** or **Auto**, **16:9**, **Full**, **Zoom**, and **Native**.

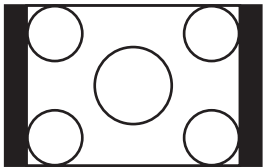
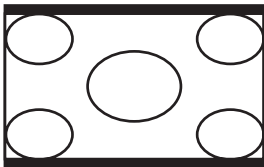
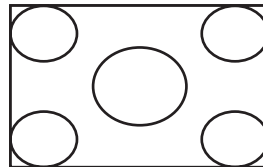
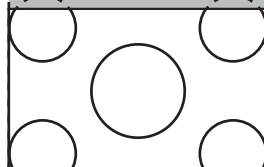
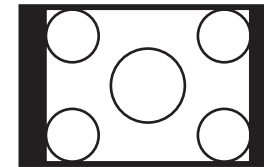
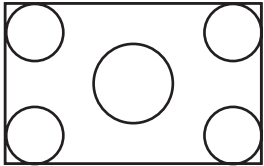
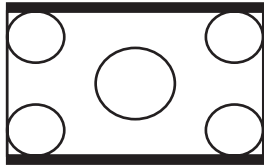
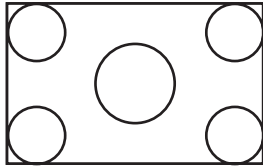
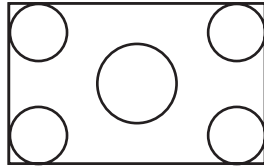
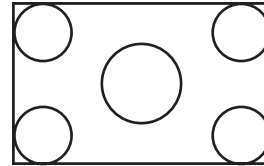
Computer Input		Projector Aspect Setting				
Resolution	Aspect Ratio	Normal/Auto*	16:9	Full	Zoom	Native
XGA (1024x768)	4:3					
WXGA (1280x800)	16:10					

* Only available when the source is HDMI.

For EB-1750

Each time the button is pressed, the aspect ratio changes in the order **Normal**, **4:3**, and **16:9**.

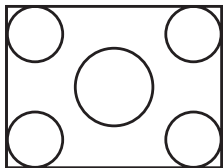
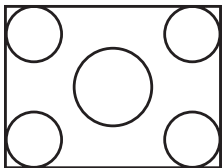
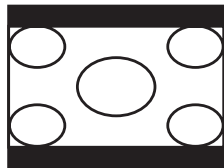
Computer Input		Projector Aspect Setting		
Resolution	Aspect Ratio	Normal	4:3	16:9
XGA (1024x768)	4:3			

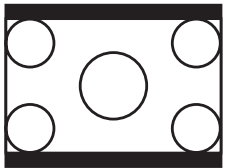
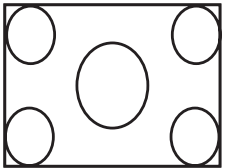
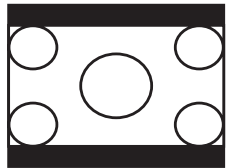
Computer Input		Projector Aspect Setting		
Resolution	Aspect Ratio	Normal	4:3	16:9
WXGA (1280x800)	16:10			



If parts of the image are missing, set the **Resolution** setting to **Wide** or **Normal** from the Configuration menu, according to the size of the computer panel.

☛ **Signal - Resolution** [p.71](#)



Useful Functions

This chapter explains useful tips for giving presentations, and the Security functions.

Projecting Without a Computer (Slideshow)

By connecting a USB storage device such as a USB memory or a USB hard disk to the projector, you can project the files stored on the device without using a computer. This function is called Slideshow.

You can make presentations with just a USB storage device and the projector by converting PowerPoint files to scenarios using the supplied EasyMP Slide Converter, and then saving them to the USB storage device.



- You may not be able to use USB storage devices that incorporate security functions.
- You cannot correct keystone distortion while projecting a Slideshow, even if you press the [Z], [V], [M], and [D] buttons on the control panel.

Type	File Type (Extension)	Notes
	.png	Cannot project images with a resolution greater than 1280x800.
Scenario file	.fse	PowerPoint files are converted to this format in EasyMP Slide Converter.
	.sit	PowerPoint files are converted to this format using simplified conversion in EasyMP Slide Converter. None of the PowerPoint animation effects are converted.



- When connecting and using a USB-compatible hard disk, make sure you connect the AC adaptor supplied with the hard disk.
- The projector does not support some file systems, so use media that has been formatted in Windows.
- Format the media in FAT16/32.

Specifications for files that can be projected using Slideshow

Type	File Type (Extension)	Notes
Image	.jpg	The following cannot be projected. - CMYK color mode formats - Progressive formats - Images with a resolution greater than 8192x8192 Due to the characteristics of JPEG files, images may not be projected clearly if the compression ratio is too high.
	.bmp	Cannot project images with a resolution greater than 1280x800.
	.gif	<ul style="list-style-type: none"> • Cannot project images with a resolution greater than 1280x800. • Cannot project animated GIFs.

Slideshow examples

Projecting images stored on USB storage



☛ "Projecting the selected image" [p.48](#)

☛ "Projecting image files in a folder in sequence (Slideshow)" [p.49](#)

Projecting PowerPoint files converted in EasyMP Slide Converter

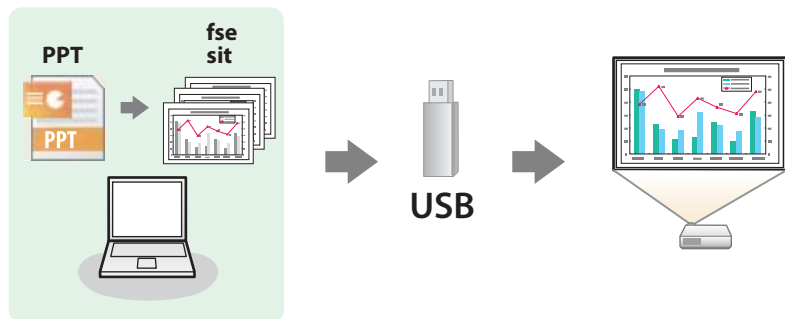

See the following manual for more information on converting PowerPoint files to scenarios using EasyMP Slide Converter.

[EasyMP Slide Converter Operation Guide](#)

Slideshow operating methods







Although the following steps are explained based on the remote control, you can perform the same operations from the control panel.

Starting Slideshow

- 1** Change the projected image to USB.
 - ☛ "Switching to the Target Image by Remote Control" [p.28](#)
- 2** Connect the USB storage device or digital camera to the projector.
 - ☛ "Connecting USB Devices" [p.23](#)



Slideshow starts and the file list screen is displayed.

- JPEG files are displayed as thumbnails (file contents are displayed as small images).
- Scenarios (FSE files and SIT files) are displayed as thumbnails as the first image in the slide.
- Other files or folders are displayed as icons as shown in the following table.

Icon	File	Icon	File
	FSE files*		BMP files
	SIT files*		GIF files
	JPEG files*		PNG files

* When it cannot be displayed as a thumbnail, it is displayed as an icon.



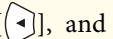
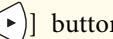

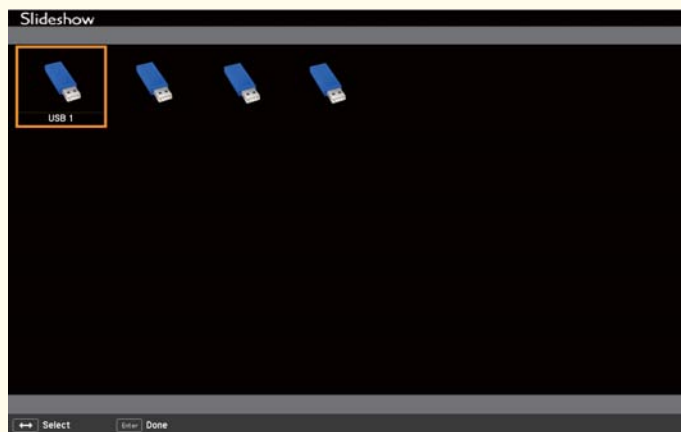
- When AutoRun is set for a scenario, it is automatically played back with the highest priority over other input sources. If you want to stop it from playing back, press the [Esc] button on the remote control.
- You can also insert a memory card into a USB card reader and then connect the reader to the projector. However, some commercially available USB card readers may not be compatible with the projector.
- If the following screen (Select Drive screen) is displayed, press the , , , and  buttons to select the drive you want to use, and then press the [Enter] button.



- To display the Select Drive screen, position the cursor on **Select Drive** at the top of the file list screen, and then press the [Enter] button.

Projecting images

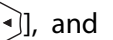
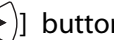
- 1 Use the , , , and  buttons to select the file or folder you want to project.



If not all of the files and folders are displayed on the current screen, press the [Down] button on the remote control, or position the cursor on **Next Page** at the bottom of the screen and press the [Enter] button.

To return to the previous screen, press the [Up] button on the remote control, or position the cursor on **Previous Page** at the top of the screen and press the [Enter] button.

- 2 Press the [Enter] button.

The selected image is displayed.

When a folder is selected, the files in the selected folder are displayed. To return to the previous screen, position the cursor on **Back to Top** and press the [Enter] button.

Rotating images

You can rotate the played images in 90° increments. The rotating function is also available during Slideshow.

- 1 Play images, or run Slideshow.

- 2** While projecting, press the [▲] or [▼] button.

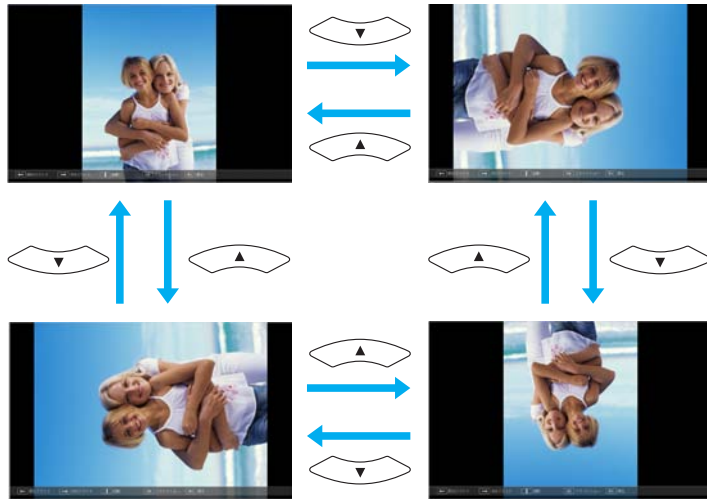

Stopping Slideshow

To close Slideshow, disconnect the USB device from the USB port on the projector. For digital cameras, hard disks, and so on, turn off the power to the device and then remove.

Projecting the selected image

Attention

Do not disconnect the USB storage device while it is being accessed. An error may occur in Slideshow.

- 1** Start Slideshow.
The file list screen is displayed.
☛ "Starting Slideshow" p.46

- 2** Press the [▲], [▼], [◀], and [▶] buttons to select the image file you want to project.



- 3** Press the [Enter] button.
The image is displayed.

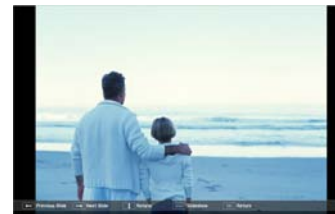

Press the [▶] and [◀] buttons to move to the next or previous image file.



- 4** Press the [Esc] button to return to the file list screen.

Projecting image files in a folder in sequence (Slideshow)

You can project the image files in a folder in sequence, one at a time. This function is called Slideshow. Use the following procedure to run Slideshow.





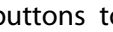

To change files automatically when you run Slideshow, set **Screen Switching Time** from **Option** in Slideshow to anything other than **No**. The default setting is 3 seconds.

- 1** Start Slideshow.
The file list screen is displayed.
☛ "Starting Slideshow" [p.46](#)
- 2** Use the [][][][] buttons to position the cursor over the folder for the Slideshow that you want to run and press the [Enter] button.
- 3** Select **Slideshow** at the bottom right of the file list screen, and then press the [Enter] button.
Slideshow starts, and the image files in the folder are automatically projected in sequence, one at a time.
When the last file is projected, the file list is displayed again automatically. If you set **Continuous Play** to **On** in the Option window, projection starts again from the beginning again when it reaches the end.
☛ "Image file display settings and Slideshow operation settings" [p.50](#)
You can proceed to the next screen, return to the previous screen, or stop playback while projecting a Slideshow.



If **Screen Switching Time** on the **Option** screen is set to **No**, files do not change automatically when you select Play Slideshow. Press the [] button, the [Enter] button, or the [Down] button on the remote control to continue to the next file.

Playing a scenario

- 1** Start Slideshow.
The file list screen is displayed.
☛ "Starting Slideshow" [p.46](#)
- 2** Press the [], [], [], and [] buttons to select the scenario you want to playback.
- 3** Press the [Enter] button.
Playback starts.

Operating procedures during scenario playback

Screen switching

For FSE files

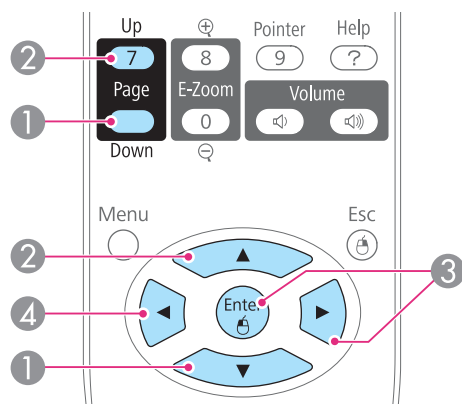

- ① Next Slide
- ② Previous Slide
- ③ Next Slide or Animation
- ④ Previous Slide or Animation

The following functions can be used when projecting a scenario or image file with Slideshow.

- Freeze
 - ☛ "Freezing the Image (Freeze)" [p.52](#)
- A/V Mute
 - ☛ "Hiding the Image and Sound Temporarily (A/V Mute)" [p.51](#)
- E-Zoom
 - ☛ "Enlarging Part of the Image (E-Zoom)" [p.53](#)



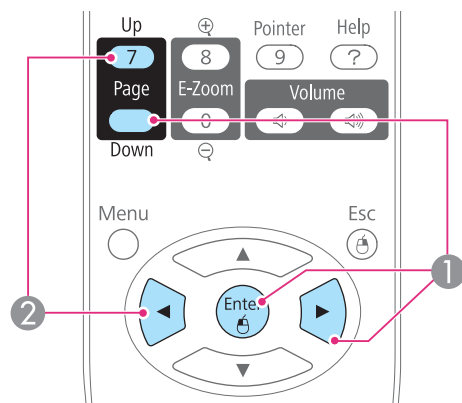

For SIT files



- ① Next Slide
- ② Previous Slide

Image file display settings and Slideshow operation settings

You can set the file display order and Slideshow operations on the Option screen.

1 Press the [][][][] buttons to position the cursor over the folder where you want to set display conditions and press the [Esc] button. Select **Option** from the submenu displayed, then press the [Enter] button.

2 When the following Option screen is displayed, set each of the items.

Enable settings by positioning the cursor on the target item and pressing the [Enter] button.

The following table shows the details for each item.

Stopping playback

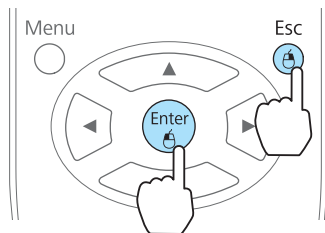

The message "Do you want to quit playing the scenario?" is displayed when you press the [Esc] button. Close by selecting **Exit** and pressing the [Enter] button.

Continue playback by selecting **Return** and pressing the [Enter] button.



Display Order	You can select to display the files in Name Order or Date Order .
Sort Order	You can select to sort the files In Ascending or In Descending order.
Continuous Play	You can set whether to repeat the Slideshow.
Screen Switching Time	You can set the time for a single file to be displayed in Play Slideshow. You can set a time between No (0) to 60 Seconds. When you set No , auto play is disabled.
Effect	You can set the screen effects when changing slides.

3 When you have finished making settings, use the [Up], [Down], [Left], and [Right] buttons to position the cursor over **OK** and press [Enter].

The settings are applied.

If you do not want to apply the settings, position the cursor on **Cancel** and press the [Enter] button.

Hiding the Image and Sound Temporarily (A/V Mute)

You can use this when you want to focus the audience's attention on what you are saying, or if you do not want to show details such as when you are changing between files during presentations from a computer.

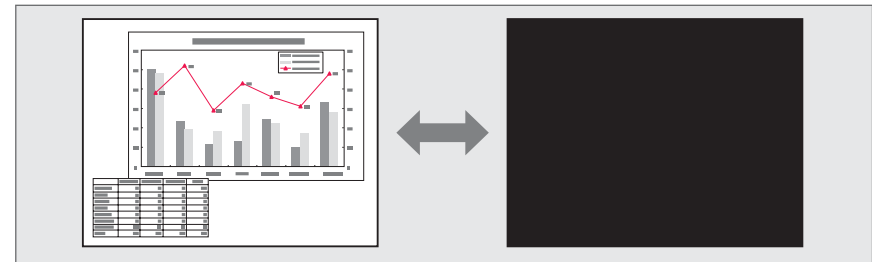

Each time you press the [A/V Mute] button, or open/close the lens cover A/V Mute turns on or off.

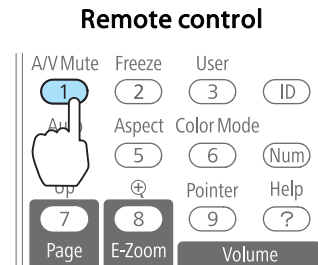

Projector

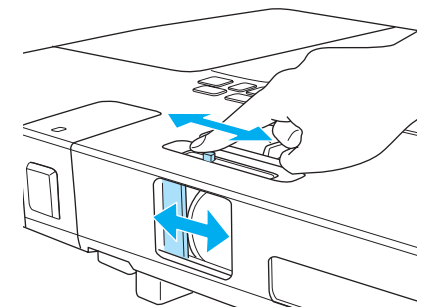



- If you use this function when projecting moving images, the images and sound continue to be played back by the source, and you cannot return to the point where A/V Mute was activated.
- You can select the screen displayed when the [A/V Mute] button is pressed from the Configuration menu.
 - ☛ **Extended - Display - A/V Mute p.74**
- When the A/V mute slide is closed for approximately 30 minutes, Lens Cover Timer activates and the power is automatically turned off. If you do not want Lens Cover Timer to activate, set **Lens Cover Timer to Off**.
 - ☛ **Extended - Operation - Lens Cover Timer p.74**
- The lamp is still lit during A/V Mute, so the lamp hours continue to accumulate.



- Audio does not stop.
- For moving images, the images continue to play back while the screen is frozen, so it is not possible to resume projection from the point where the screen was frozen.
- If the [Freeze] button is pressed while the Configuration menu or the Help screen is displayed, the menu or the Help screen that is displayed is closed.
- Freeze still works while E-Zoom is being used.

Freezing the Image (Freeze)

When Freeze is activated on moving images, the frozen image continues to project on the screen, so you can project a moving image one frame at a time like a still photo. Also, you can perform operations such as changing between files during presentations from a computer without projecting any images if the Freeze function is activated beforehand.

Each time you press the [Freeze] button, Freeze turns on or off.

Remote control

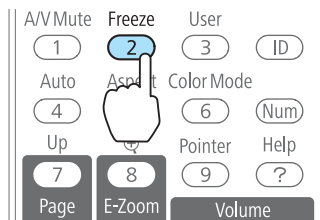

Pointer Function (Pointer)

This allows you to move a Pointer icon on the projected image, and helps you draw attention to the area you are talking about.

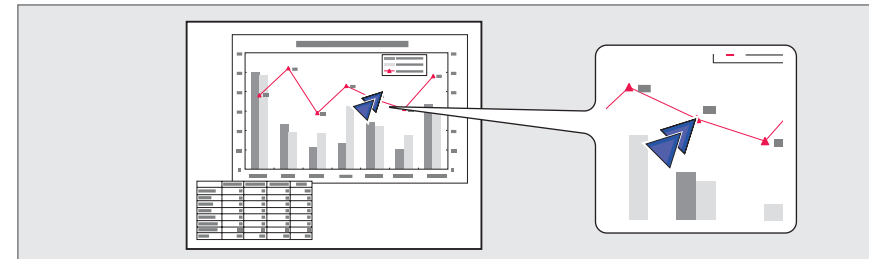

1 Display the Pointer.

Each time you press the [Pointer] button, the pointer appears or disappears.

Remote control

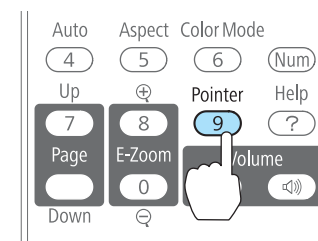

2 Move the Pointer icon (↗).

Remote control

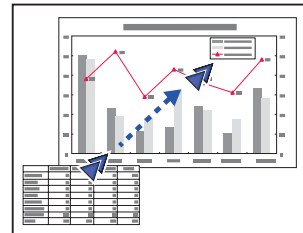
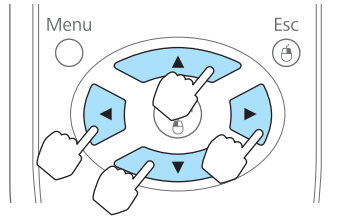

When pressed in conjunction with the adjacent [▲], [▼], [◀], and [▶] buttons, the pointer can be moved diagonally.



You can use **Pointer Shape** to set the shape of the pointer icon.

🖱️ **Settings - Pointer Shape** [p.73](#)

Enlarging Part of the Image (E-Zoom)

This is useful when you want to expand images to see them in greater detail, such as graphs and tables.

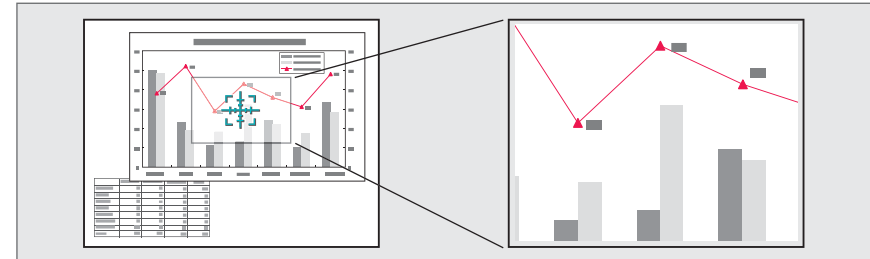

1 Start E-Zoom.

Press the [⊕] button to display the Cross (⊕).

Remote control

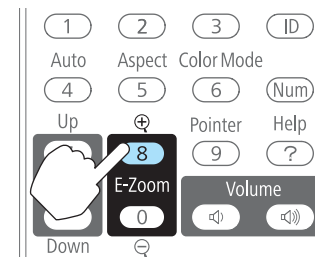

- 2** Move the Cross (⊕) to the area of the image that you want to enlarge.

Remote control

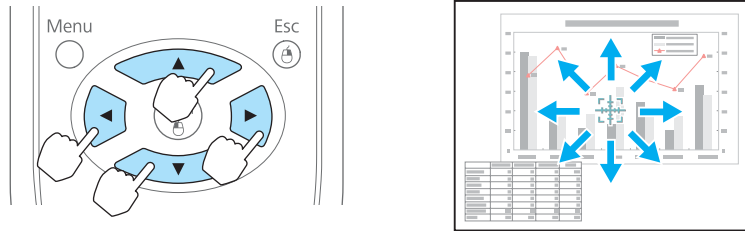

When pressed in conjunction with the adjacent [⬆], [⬇], [⬅], and [➡] buttons, the pointer can be moved diagonally.

- 3** Enlarge.

Remote control

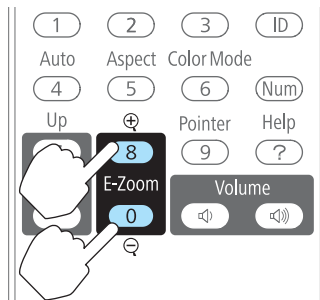

[⊕] button: Expands the area each time it is pressed. You can expand quickly by holding the button down.

[⊖] button: Reduces images that have been enlarged.

[Esc] button: Cancels E-Zoom.



- The enlargement ratio appears on the screen. The selected area can be enlarged to between 1 to 4 times in 25 incremental steps.
- During enlarged projection, press the [⬆], [⬇], [⬅], and [➡] buttons to scroll the image.
- If E-Zoom is selected, **Progressive** and **Noise Reduction** are cancelled.

Using the Remote Control to Operate the Mouse Pointer (Wireless Mouse)

When the USB port of a computer and the USB (TypeB) port on the projector are connected with the supplied USB cable, you can use the remote control to control the computer's mouse pointer.

This is only available when the source is Computer or HDMI (EB-1775W/EB-1770W/EB-1760W only).

☛ "Connecting a Computer" [p.21](#)

To activate the Wireless Mouse function, set **USB Type B** to **Link 21L**. By default, **USB Type B** is set to **USB Display**. Change the setting beforehand.

☛ **Extended - USB Type B** [p.74](#)

The following operating systems are compatible with Wireless Mouse.

	Windows	Mac OS
OS	Windows 98	Mac OS X 10.3.x
	Windows 98SE	Mac OS X 10.4.x
	Windows Me	Mac OS X 10.5.x
	Windows 2000	Mac OS X 10.6.x
	Windows XP	
	Windows Vista	
	Windows 7	

* It may not be possible to use the Wireless Mouse function under some versions of the operating systems.

Once the connection has been made, the mouse pointer can be operated as follows.

Moving the mouse pointer

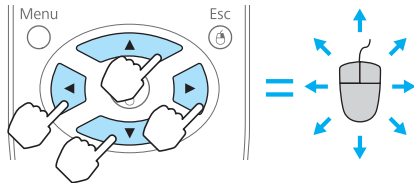

[Up] [Down] [Left] [Right] buttons:
Moves the mouse pointer.

Mouse clicks

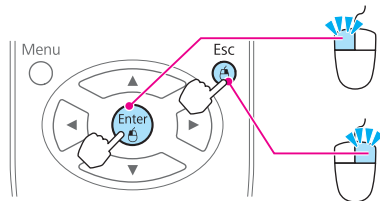

[Enter] button: Left click. Press quickly twice to double-click.

[Esc] button: Right click.

Drag and drop

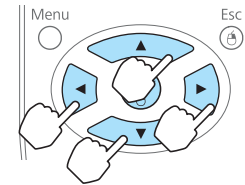

While holding down the [Enter] button, press the [Up], [Down], [Left], and [Right] buttons.

Release the [Enter] button to drop at the desired location.



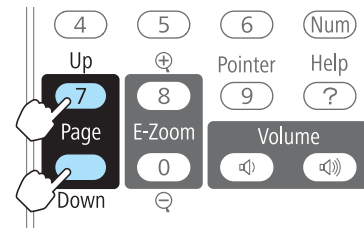

Page Up/Down



[Up] button: Moves to the previous page.

[Down] button: Moves to the next page.









- When pressed in conjunction with the adjacent [, [, [, and [] buttons, the pointer can be moved diagonally.
- If the mouse button settings are set to reverse on the computer, the operation of the remote control buttons will also be reversed.
- The Wireless Mouse function cannot be used while the following functions are being used.
 - While the Configuration menu is being displayed
 - While a help menu is being displayed
 - While the E-Zoom function is being used
 - While a user's logo is being captured
 - While a pointer function is being used
 - While adjusting sound volume
 - While USB Display is being operated
 - While displaying a Test Pattern
 - While Color Mode is being set
 - While Color Mode name is being displayed
 - While the Source name is being displayed
 - While switching input source

Setting the ID and Using the Remote Control

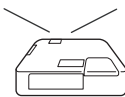
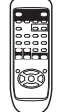
When an ID is set for the projector and the remote control, you can use the remote control to operate only the projector with a matching ID. This is useful when managing multiple projectors.

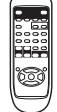
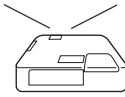
You can set an ID for the projector within a range of "1" to "9". The default value is Off.

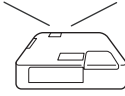
You can set an ID for the remote control within a range of "0" to "9". The default value is "0". The following table shows the possible combinations of Projector ID and remote control ID.

Operation	Combinations		Descriptions
Possible		Projector ID: 1	The projector ID and the remote control ID are identical, therefore you can operate the projector with the remote control.
		Remote control ID: 1	
Possible		Projector ID: Off	When the Projector ID is Off, you can operate with the remote control regardless of the remote control ID setting.
		Remote control ID: 1	
Possible		Projector ID: 1	When the remote control ID is "0", you can operate with the remote control regardless of the Projector ID setting.
		Remote control ID: 0	
Not possible		Projector ID: 1	The Projector ID and the remote control ID do not match, therefore you cannot operate the projector with the remote control.
		Remote control ID: 3	

Setting the Projector ID

- 1 Press the [Menu] button while projecting.
 ☛ "Using the Configuration Menu" p.67

Using the remote control

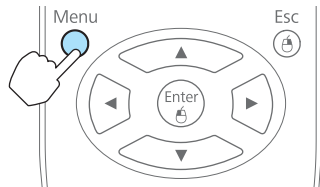

Using the control panel

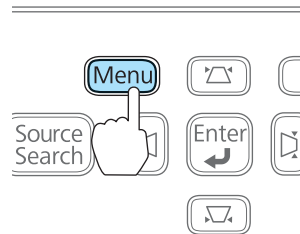

- 2 Select **Projector ID** from **Extended**.

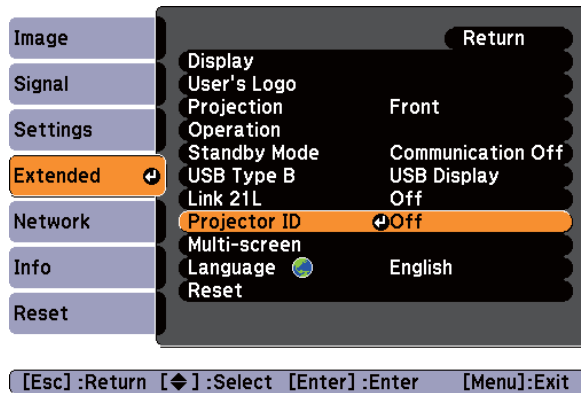

- 3 Choose the ID you want to set and press the [Enter] button.

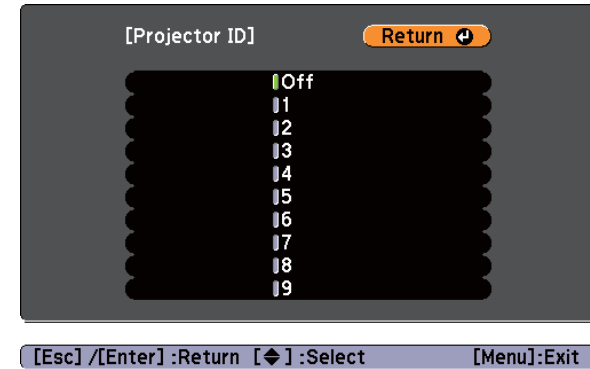

- 4 Press the [Menu] button to finish making settings.

Setting the remote control ID

Set the ID on the remote control each time you switch the projector power on. When the projector is powered on, the remote control ID is set to "0" (that is, you can operate the projector with the remote control regardless of the projector ID).

- 1 Point the remote control at the remote receiver of the target projector and press the [ID] button on the remote control.

When you press the [ID] button, the current Projector ID is displayed on the projection screen. It disappears in about three seconds.

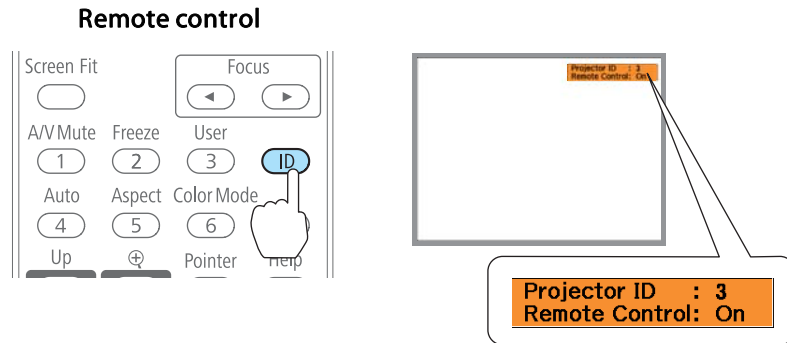

- 2 While holding the [ID] button, press the number button that matches the ID of the projector you want to operate.

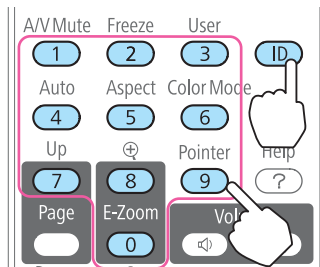

Once this setting has been made, the projector that can be operated by the remote control is limited.



When you power off the projector, the remote control ID is reset to "0" (that is, you can operate the projector with the remote control regardless of the projector ID).

Correcting Color when Projecting from Multiple Projectors

When multiple projectors are lined up and projecting images, you can correct the brightness and color tone of each projector's image with multi-screen color adjustment so that the colors of images from each projector match closely.



In some cases the brightness and color tone may not match completely even after correction.

Summary of correction procedure

When multiple projectors are set up and you need to make corrections, use the following procedure to correct one projector at a time.

1. **Set the projector ID and the remote control ID.**

Set a projector ID for the target projector, then set the same ID for the remote control, so that you can limit the operation to one target projector.

☞ "Setting the ID and Using the Remote Control" [p.56](#)

2. **Correct the color difference.**

You can carry out color correction when projecting from multiple projectors. You can adjust from black to white in five stages called levels 1 to 5, and in each of these 5 levels you can adjust the following two points.

- Correcting brightness
You can correct the image brightness to make them all equal.
- Correcting color
You can correct the image color so that they match closely.

Correcting

After setting up the projectors, correct the brightness and tone for each projector to reduce the differences.

- 1 Press the [Menu] button.
 - ☛ "Using the Configuration Menu" p.67

- 2 Select **Multi-screen** from **Extended**.

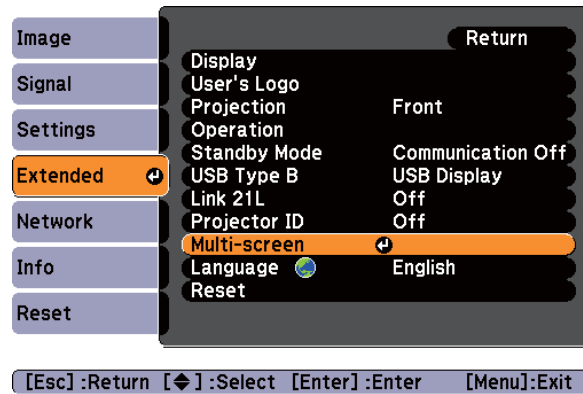

- 3 Select the level to be corrected in **Adjustment Level**.

- Each time a level is selected, the pattern of the level selected is displayed.
- You can start correcting from any level, usually you can make it darker or lighter by correcting 1 to 5 or 5 to 1.

- 4 Correct the brightness with **Brightness Correct**.

- When you select **Level 5**, all the images are adjusted to the darkest image from multiple projectors.
- When you select **Level 1**, all the images are adjusted to the brightest image from multiple projectors.
- When you select **Level 2 to Level 4**, all the images are adjusted to the mid-range brightness image from multiple projectors.
- Because each time the [Enter] button is pressed the image displayed changes between the pattern display and the actual image, you can check the correction results and make corrections in the actual image.

- 5 Correct the **Color Correct. (G/R)** and **Color Correct. (B/Y)** settings.

- 6 Repeat procedures 3 to 5 until corrections are finished.

- 7 When all corrections are finished, press the [Menu] button to finish making settings.

Saving a User's Logo

You can save the image that is currently being projected as a User's Logo.



Once a User's Logo has been saved, the logo cannot be returned to the factory default.

- 1 Project the image you want to save as the User's Logo, and then press the [Menu] button.

☛ "Using the Configuration Menu" p.67

Using the remote control

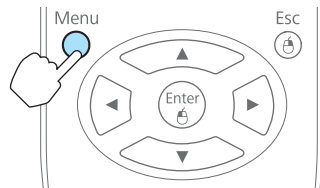

Using the control panel

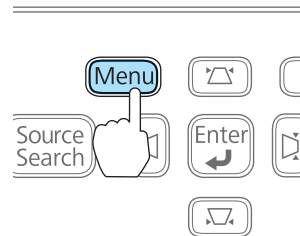

- 2 Select **User's Logo** from **Extended**.

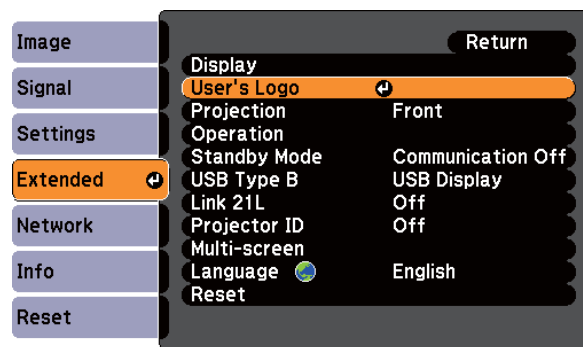

[Esc] :Return [↔] :Select [Enter] :Enter [Menu] :Exit



- When **User's Logo Protect** from **Password Protect** is set to **On**, a message is displayed and the User's Logo cannot be changed. You can make changes after setting **User's Logo Protect** to **Off**.

☛ "Managing Users (Password Protect)" p.62

- If **User's Logo** is selected when Keystone, E-Zoom, Aspect, Progressive, or Zoom are being performed, the function currently being performed is cancelled.

- 3 When the message "Choose this image as the User's Logo?" is displayed, select **Yes**.



When you press the [Enter] button on the remote control or the control panel, the screen size may change depending on the signal to match the actual resolution of the image signal.

- 4 Move the box to select the part of the image to use as the User's Logo.

You can perform the same operations from the projector's control panel.

Remote control

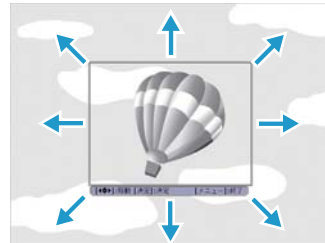
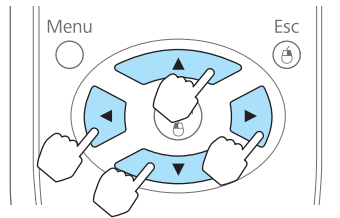

You can save at 400x300 dots in size.

- 5** When you press the [Enter] button and the message "Select this image?" is displayed, select **Yes**.

- 6** Select the zoom factor from the zoom setting screen.

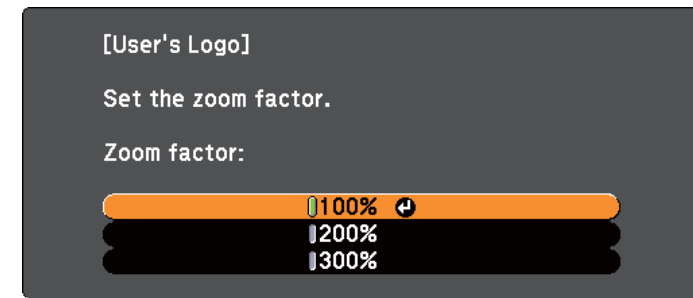

[Esc]:Return [◆]:Select [Enter]:Set [Menu]:Exit

- 7** When the message "Save this image as the User's Logo?" is displayed, select **Yes**.

The image is saved. After the image has been saved, the message "Completed." is displayed.



- When a User's Logo is saved, the previous User's Logo is erased.
- Saving the User's Logo may take approximately 15 seconds. Do not operate the projector or any connected equipment while it is saving, otherwise malfunctions may occur.

The projector has the following enhanced security functions.

- **Password Protect**
You can limit who can use the projector.
- **Control Panel Lock**
You can prevent people changing the settings on the projector without permission.
☛ "Restricting Operation (Control Panel Lock)" [p.64](#)
- **Anti-Theft Lock**
The projector is equipped with the following anti-theft security device.
☛ "Anti-Theft Lock" [p.65](#)

Managing Users (Password Protect)

When Password Protect is activated, people who do not know the password cannot use the projector to project images even if the projector power is on. Furthermore, the user's logo that is displayed when you turn on the projector cannot be changed. This acts as an anti-theft device as the projector cannot be used even if it is stolen. At the time of purchase, Password Protect is not activated.

Kinds of Password Protect

The following three kinds of Password Protect settings can be made according to how the projector is being used.

- **Power On Protect**
When **Power On Protect** is **On**, you need to enter a preset password after the projector is plugged in and turned on (this also applies to Direct Power On). If the correct password is not entered, projection does not start.

- **User's Logo Protect**

Even if someone tries to change the User's Logo set by the owner of the projector, it cannot be changed. When **User's Logo Protect** is set to **On**, the following setting changes for the User's Logo are prohibited.

- Capturing a User's Logo
- Setting **Display Background**, **Startup Screen**, or **A/V Mute** from **Display**
☛ **Extended - Display** [p.74](#)
- **Network Protect** (EB-1775W/EB-1770W/EB-1760W only)
When **Network Protect** is set to **On**, changing the settings for **Network** is prohibited.
☛ "Network Menu (EB-1775W/EB-1770W/EB-1760W Only)" [p.76](#)

Setting Password Protect

Use the following procedure to set Password Protect.

- 1 During projection, hold down the [Freeze] button for about five seconds.

The Password Protect setting menu is displayed.

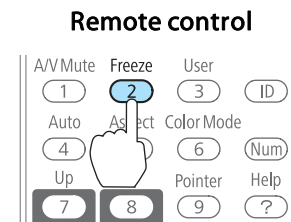



- If Password Protect is already activated, you must enter the password.
If the password is entered correctly, the Password Protect setting menu is displayed.
- "Entering the Password" p.63
- When the password is set, stick the supplied password protect sticker in a visible position on the projector as a further theft deterrent.

- 2** Select the type of Password Protect you want to set, and then press the [Enter] button.

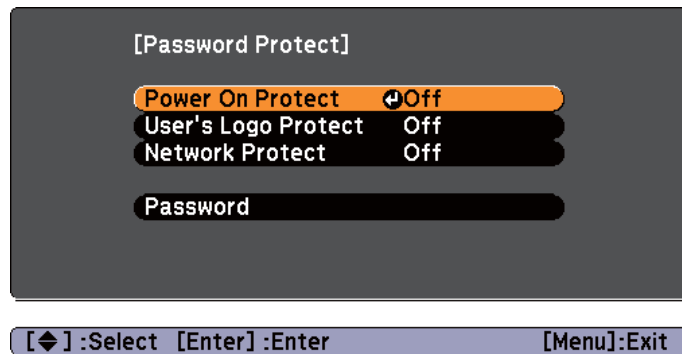

- 3** Select **On**, and then press the [Enter] button.
Press the [Esc] button, the screen displayed in step 2 is displayed again.
- 4** Set the password.
- (1) Select **Password**, and then press the [Enter] button.
 - (2) When the message "Change the password?" is displayed, select **Yes** and then press the [Enter] button. The default password is set to "0000". Change this to your own desired password. If you select **No**, the screen displayed in step 2 is displayed again.

- (3) While holding down the [Num] button, enter a four digit number using the numeric buttons. The number entered is displayed as "****". When you enter the fourth digit, the confirmation screen is displayed.

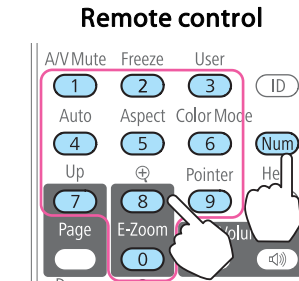

- (4) Re-enter the password.
The message "Password accepted." is displayed.
If you enter the password incorrectly, a message is displayed prompting you to re-enter the password.

Entering the Password

When the password entry screen is displayed, enter the password using the numeric buttons on the remote control.

While holding down the [Num] button, enter the password by pressing the numeric buttons.

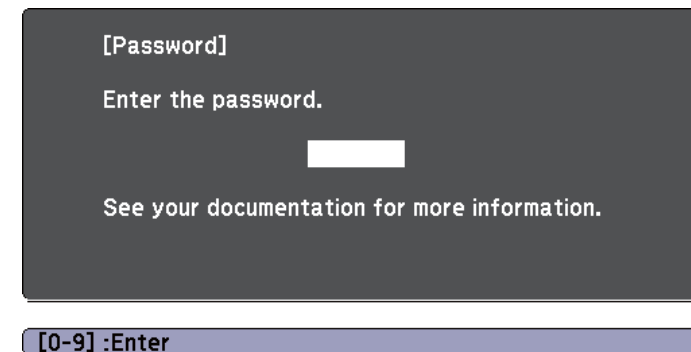

When you enter the correct password, Password Protect is temporarily released.

Attention

- If an incorrect password is entered three times in succession, the message "The projector's operation will be locked." is displayed for approximately five minutes, and then the projector switches to standby mode. If this happens, disconnect the power plug from the electrical outlet and then reinsert it and turn the projector's power back on. The projector displays the password entry screen again so that you can enter the correct password.
- If you have forgotten the password, make a note of the "Request Code: xxxxx" number that appears on the screen and contact the nearest address provided in the *Epson Projector Contact List*.
[Epson Projector Contact List](#)
- If you continue to repeat the above operation and input the wrong password thirty times in succession, the following message is displayed and the projector does not accept any more password entries. "The projector's operation will be locked." "Contact Epson as described in your documentation."
[Epson Projector Contact List](#)

This is useful at events or shows when you want to deactivate all buttons during projection or at schools when you want to limit button operation. The projector can still be operated using the remote control.

1 Press the [Menu] button while projecting.

"Using the Configuration Menu" [p.67](#)

Using the remote control

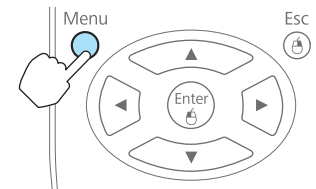

Using the control panel

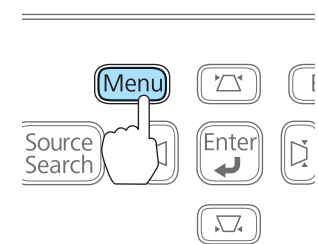

2 Select **Control Panel Lock** from **Settings**.

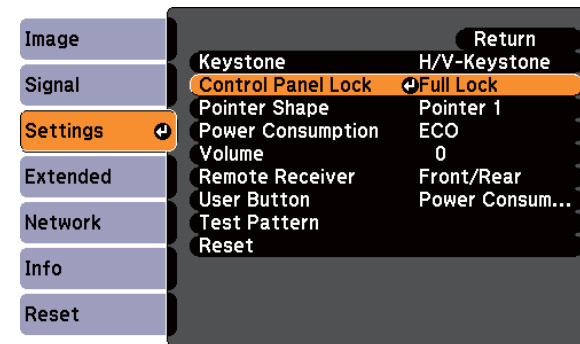

[Esc]:Return [◆]:Select [Enter]:Enter [Menu]:Exit

3 Select either **Full Lock** or **Partial Lock** according to your purpose.

Restricting Operation (Control Panel Lock)

Perform one of the following to lock the operation buttons on the control panel.

- Full Lock
All of the buttons on the control panel are locked. You cannot perform any operations from the control panel, including turning the power on or off.
- Partial Lock
All of the buttons on the control panel, except for the [⏻] button, are locked.

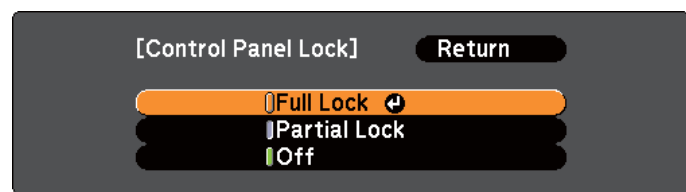

- 4** Select **Yes** when the confirmation message is displayed.
The control panel buttons are locked according to the setting you chose.



You can release the control panel lock by one of the following two methods.

- Select **Off** from **Control Panel Lock**.
 👉 **Settings - Control Panel Lock** p.73
- Press and hold down the [Enter] button on the control panel for about seven seconds, a message is displayed and the lock is released.

Anti-Theft Lock

As an anti-theft measure, the projector is equipped with a security slot compatible with the Microsaver Security System manufactured by Kensington.

See the following for more details on the Microsaver Security System.

👉 <http://www.kensington.com/>



Configuration Menu

This chapter explains how to use the Configuration menu and its functions.

This section explains how to use the Configuration menu.

Although steps are explained using the remote control as an example, you can perform the same operations from the control panel. Check the guide under the menu for the available buttons and their operations.

1 Display the Configuration menu screen.

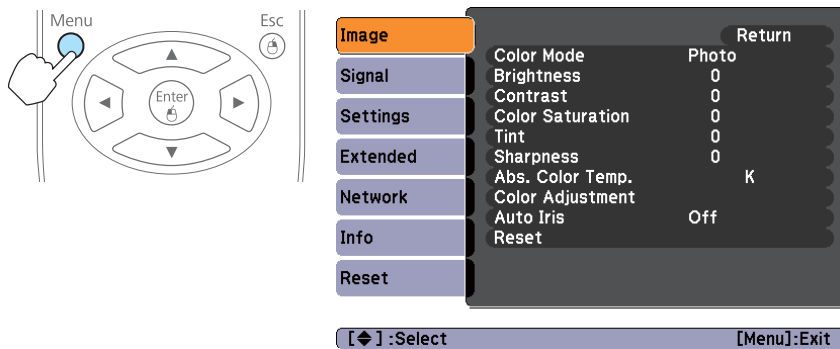

2 Select a top menu item.

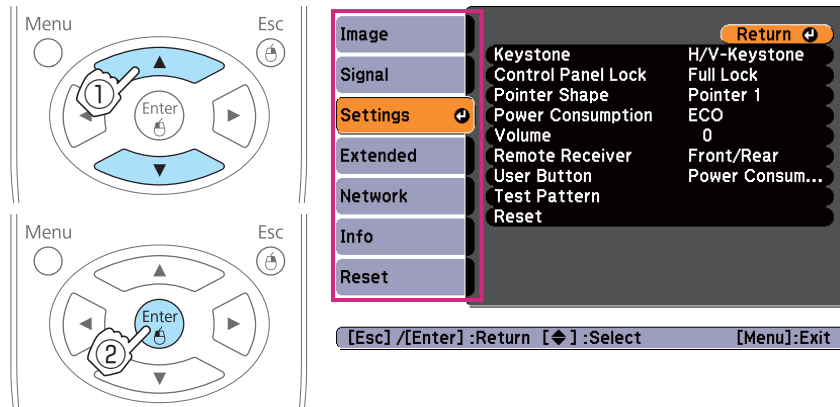

3 Select a submenu item.

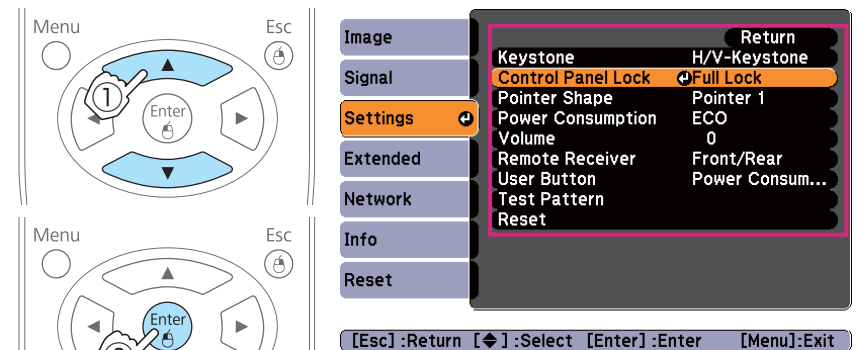

4 Change settings.

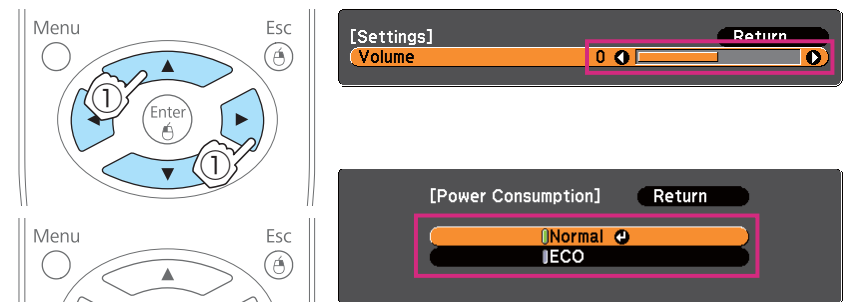

5 Press the [Menu] button to finish making settings.

Configuration Menu Table

Settable items vary depending on the model being used and the image signal and source being projected.

Top Menu Name	Submenu Name	Setting Values
Image menu ☛ p.70	Color Mode	Dynamic, Presentation, Theatre, Photo, sRGB, Blackboard, Whiteboard, and Customized
	Brightness	-24 to 24
	Contrast	-24 to 24
	Color Saturation	-32 to 32
	Tint	-32 to 32
	Sharpness	-5 to 5
	Abs. Color Temp.	5000K to 10000K
	Color Adjustment	R: -16 to 16 G: -16 to 16 B: -16 to 16
Auto Iris	On and Off	
Signal menu ☛ p.71	Auto Setup	On and Off
	Resolution	Auto, Wide, and Normal
	Tracking	1216 to 1470
	Sync.	0 to 31
	Position	Up, Down, Left, and Right
	Progressive	Off, Video, and Film/Auto
	Noise Reduction	Off, NR1, and NR2
	HDMI Video Range	Auto, Normal, and Expanded
Input Signal	Auto, RGB, and Component	

Top Menu Name	Submenu Name	Setting Values
	Video Signal	Auto, NTSC, NTSC4.43, PAL, M-PAL, N-PAL, PAL60, and SECAM
	Aspect	Normal, 4:3, 16:9, Full, Zoom, and Native
	Overscan	Auto, Off, 4%, and 8%
Settings menu ☛ p.73	Keystone	H/V-Keystone and Quick Corner
	Control Panel Lock	Full Lock, Partial Lock, and Off
	Pointer Shape	Pointer 1, 2, and 3
	Power Consumption	Normal and ECO
	Volume	0 to 20
	Remote Receiver	Front/Rear, Front, Rear and Off
	User Button	Power Consumption, Info, Progressive, Test Pattern, Multi-screen, and Resolution
Test Pattern	-	
Extended menu ☛ p.74	Display	Messages, Display Background, Startup Screen, and A/V Mute
	User's Logo	-
	Projection	Front, Front/Ceiling, Rear, and Rear/Ceiling
	Operation	Direct Power On, Sleep Mode, Sleep Mode Timer, Lens Cover Timer, and High Altitude Mode
	Standby Mode	Communication On and Communication Off
	USB Type B	USB Display and Link 21L
	Link 21L	On and Off
	Projector ID	Off and 1 to 9

Top Menu Name	Submenu Name	Setting Values
	Multi-screen	Adjustment Level, Brightness Correct., Color Correct. (G/R), and Color Correct. (B/Y)
	Language	15 or 35 languages*1
Info menu ☛ p.84	Lamp Hours	-
	Source	-
	Input Signal	-
	Resolution	-
	Video Signal	-
	Refresh Rate	-
	Sync Info	-
	Status	-
	Serial Number	-
	Event ID	-
Reset menu ☛ p.84	Reset All	-
	Reset Lamp Hours	-

*1 The number of supported languages differs depending on the region where the projector is purchased.

Network menu (EB-1775W/EB-1770W/EB-1760W only)

Top Menu Name	Submenu Name	Setting Values
Basic menu ☛ p.78	Projector Name	-
	PJLink Password	-
	Web Control Password	-
	Projector Keyword	On and Off
Wireless LAN menu ☛ p.79	Wireless LAN Power	On and Off
	Connection Mode	Quick and Advanced

Top Menu Name	Submenu Name	Setting Values
	Channel	1ch, 6ch, and 11ch
	Wireless LAN system	802.11b/g and 802.11b/g/n
	SSID Auto Setting	On and Off
	SSID	-
	IP Settings	DHCP, IP Address, Subnet Mask, and Gateway Address
	SSID Display	On and Off
	IP Address Display	On and Off
Security menu ☛ p.80	Security	None, WEP, WPA-PSK, and WPA2-PSK
	WEP Encryption	128Bit and 64Bit
	Format	ASCII and HEX
	Key ID	1, 2, 3, 4
	Encryption Key 1, Encryption Key 2, Encryption Key 3, and Encryption Key 4	-
	Authentication Type	Open and Shared
	PSK	-
Mail menu ☛ p.82	Mail Notification	On and Off
	SMTP Server	-
	Port Number	-
	Address 1 Setting, Address 2 Setting, and Address 3 Setting	-
Others menu ☛ p.82	SNMP	On and Off
	Trap IP Address 1 and Trap IP Address 2	-
	AMX Device Discovery	On and Off

Image Menu

Settable items vary depending on the image signal and source currently being projected. Setting details are saved for each image signal.

☛ "Automatically Detect Input Signals and Change the Projected Image (Source Search)" [p.27](#)

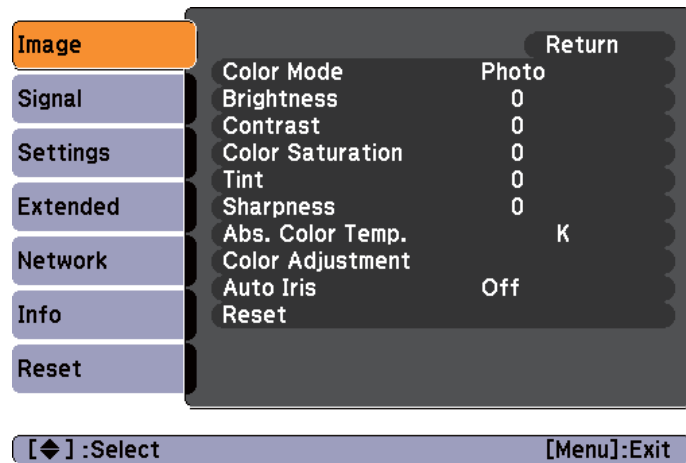

Submenu	Function
Color Mode	You can select the quality of the image to suit your surroundings. ☛ "Selecting the Projection Quality (Selecting Color Mode)" p.38
Brightness	You can adjust the image brightness.
Contrast	You can adjust the difference between light and dark in the images.
Color Saturation	You can adjust the color saturation for the images.
Tint	(Adjustment is only possible when NTSC signals are being input if you use composite video signals.) You can adjust the image tint.

Submenu	Function
Sharpness	You can adjust the image sharpness.
Abs. Color Temp.	(This item cannot be selected if Color Mode is set to sRGB ▶.) You can adjust the overall tint of the image. You can adjust tints in 10 stages from 5000 K to 10000 K. The image is tinted blue when a high value is selected and tinted red when a low value is selected.
Color Adjustment	(This item cannot be selected if Color Mode is set to sRGB ▶.) <ul style="list-style-type: none"> When Color Mode is set to anything other than Customized: You can adjust the color strength for Red, Green, and Blue individually. When Color Mode is set to Customized: You can adjust the Hue, Saturation, and Brightness for R (red), G (green), B (blue), C (cyan), M (magenta), and Y (yellow) individually.
Auto Iris	(This item can be set only if Color Mode is set to Dynamic , Theatre , or Customized .) Set to On to adjust the iris to obtain the optimum light for images being projected. The setting is stored for each Color Mode. ☛ "Setting Auto Iris" p.39
Reset	You can reset all adjustment values for the Image menu to their default settings. See the following to return all menu items to their default settings. ☛ "Reset Menu" p.84

Signal Menu

Settable items vary depending on the image signal and source currently being projected. Setting details are saved for each image signal.

You cannot make settings on the Signal menu when the source is USB Display, USB, or LAN.

☛ "Automatically Detect Input Signals and Change the Projected Image (Source Search)" [p.27](#)

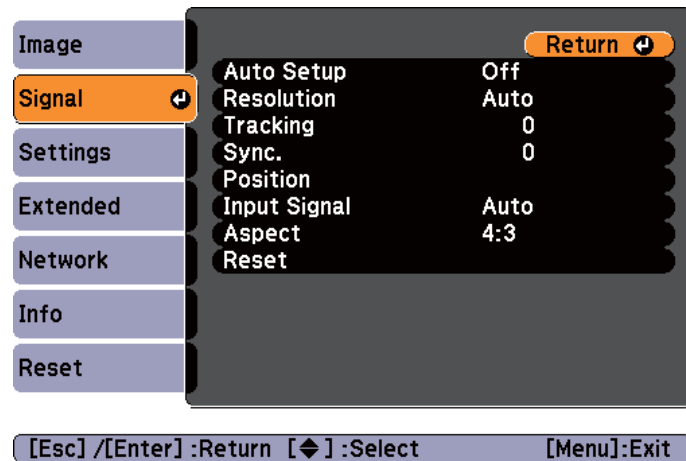

Submenu	Function
Auto Setup	Set to On to automatically adjust the image to the optimum state when the input signal changes.
Resolution	Set to Auto to automatically identify the resolution of the input signal. If images are not projected correctly when set to Auto , for example if some of the image is missing, adjust to Wide for wide screens, or set to Normal for 4:3 or 5:4 screens depending on the connected computer.
Tracking	You can adjust computer images when vertical stripes appear in the images.



Submenu	Function
Sync.	You can adjust computer images when flickering, fuzziness, or interference appear in the images.
Position	You can adjust the display position up, down, left, and right when a part of the image is missing so that the whole image is projected.
Progressive	(This setting can only be adjusted when a component video or RGB video with an interlaced signal (480i/576i/1080i) is input. This cannot be set when a digital RGB signal is input.) <u>Interlace</u> (i) signal is converted to <u>Progressive</u> (p). (IP conversion) Off: Ideal for images with a large amount of movement. Video: Ideal for general video images. Film/Auto: Ideal for movies, CG, and animation.
Noise Reduction	(This cannot be set when a digital RGB signal is input, or when an interlace signal is being displayed when Progressive is set to Off .) Smoothes out rough images. There are two modes. Select your favorite setting. It is recommended that this is set to Off when viewing image sources in which noise is very low, such as for DVDs.
HDMI Video Range (EB-1775W/ EB-1770W/ EB-1760W only)	When the projector's HDMI port is connected to a DVD player, the projector's video range is set according to the DVD player's video range setting.
Input Signal	You can select the input signal from the Computer port. If set to Auto , the input signal is set automatically according to the connected equipment. If colors do not appear correctly when set to Auto , select the appropriate signal according to the connected equipment.
Video Signal	You can select the input signal from the Video port. If this is set to Auto , video signals are recognized automatically. If interference appears in the image or a problem occurs such as no image is being projected when set to Auto , select the appropriate signal depending on the connected equipment.



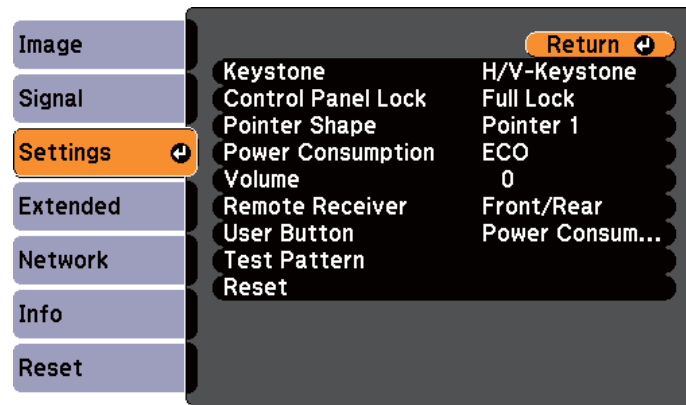

Submenu	Function
Aspect	<p>You can set the <u>aspect ratio</u> for projected images.</p> <p>☛ "Changing the Aspect Ratio" p.40</p>
Overscan	<p>(This cannot be set when a digital RGB signal is input.)</p> <p>Changes the output image ratio (the range of the projected image). You can set the cropping range to Off, 4%, or 8%. When the source is HDMI, Auto is available. When Auto is selected, it automatically changes to Off or 8% according to the input signal. However, this only occurs when the HDMI port of the connected device is connected to the projector's HDMI port.</p>
Reset	<p>You can reset all adjustment values on the Signal menu to their default settings, except for Input Signal.</p> <p>See the following to return all menu items to their default settings.</p> <p>☛ "Reset Menu" p.84</p>

Settings Menu



[Esc] / [Enter] : Return [◆] : Select [Menu] : Exit

Submenu	Function
Keystone	<p>You can correct keystone distortion.</p> <ul style="list-style-type: none"> When H/V-Keystone is selected: <ul style="list-style-type: none"> Correcting manually Adjust V-Keystone and H-Keystone to correct horizontal and vertical keystone distortion. Correcting automatically Set Auto H/V-Keystone* to On.  "Correcting automatically - Auto H/V-Keystone - (EB-1775W only)" p.33 * When using EB-1770W/EB-1760W/EB-1750, set Auto V-Keystone to On. When Quick Corner is selected: Select and correct the four corners of the projected image.  "Correcting manually - Quick Corner -" p.34
Control Panel Lock	<p>You can use this to restrict operation of the projector's control panel.</p>  "Restricting Operation (Control Panel Lock)" p.64



Submenu	Function
Pointer Shape	<p>You can select the shape of the pointer.</p> <p>Pointer 1: </p> <p>Pointer 2: </p> <p>Pointer 3: </p> <p> "Using the Remote Control to Operate the Mouse Pointer (Wireless Mouse)" p.54</p>
Power Consumption	<p>You can set the lamp brightness to one of two settings. Select ECO if the images being projected are too bright, such as when projecting images in a dark room or onto a small screen. When ECO is selected, the power consumption is changed as follows, and fan rotation noise during projection is reduced. Electrical consumption: about 27% decrease</p>
Volume	<p>You can adjust the volume. Setting values are saved for each source.</p>
Remote Receiver	<p>You can limit the reception of the operation signal from the remote control.</p> <p>When set to Off, you cannot perform any operations from the remote control. If you want to make operations from the remote control, hold down the [Menu] button on the remote control or the control panel for at least 15 seconds to reset the setting to its default value.</p>
User Button	<p>You can select and assign an item from the Configuration menu with the remote control's [User] button. Pressing the [User] button directly displays the assigned menu item selection/adjustment screen, allowing you to make one-touch changes to settings/adjustments. You can assign one of the following items to the [User] button.</p> <p>Power Consumption, Info, Progressive, Test Pattern, Multi-screen, and Resolution</p>

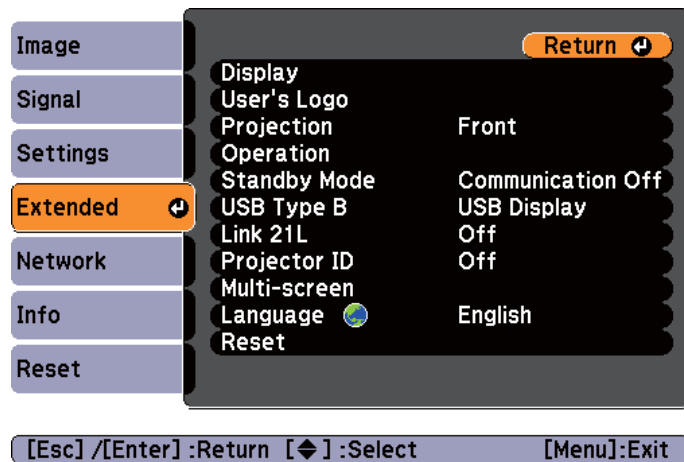

Submenu	Function
Test Pattern	You can display a test pattern to adjust the projection without connecting other equipment when you set up the projector. While the test pattern is displayed, you can adjust keystone, zoom, and focus. To cancel the test pattern, press the [Esc] button on the remote control or the control panel.
Reset	You can reset all adjustment values on the Settings menu to their default settings, except for User Button . See the following to return all menu items to their default settings. ☛ "Reset Menu" p.84

Submenu	Function
Display	You can make settings related to the projector's display. Messages: When set to Off , the following items will not be displayed. The name of the current selection when changing the source, color mode, or aspect ratio; a message when no image signal is input; warnings such as the High Temp Warning. Display Background*1: You can set the screen background to Black , Blue , or Logo when no image signal is available. Startup Screen*1: Set to On to display the User's Logo when projection starts. A/V Mute*1: You can set the screen displayed when the remote control's [A/V Mute] button is pressed to Black , Blue , or Logo .
User's Logo*1	You can change the user's logo that is displayed as a background during Display Background, A/V Mute, and so on. ☛ "Saving a User's Logo" p.60
Projection	Select from one of the following projection methods depending on how the projector is installed. Front , Front/Ceiling , Rear , and Rear/Ceiling You can change the setting as follows by pressing down the [A/V Mute] button on the remote control for about five seconds. Front ↔ Front/Ceiling Rear ↔ Rear/Ceiling ☛ "Installation Methods" p.19

Extended Menu



Submenu	Function
Operation	<p>Direct Power On: Set to On to turn on the projector simply by plugging it in.</p> <p>When the power cable is plugged in, note that the projector turns on automatically in cases such as a power outage being restored.</p> <p>Sleep Mode: When set to On, this automatically stops projection when no image signal is being input and no operations are carried out.</p> <p>Sleep Mode Timer: When Sleep Mode is set to On, you can set the time before the projector automatically turns off within a range of 1 to 30 minutes.</p> <p>Lens Cover Timer: When set to On, this turns off the power automatically 30 minutes after the A/V mute slide is closed.</p> <p>This is set to On by default.</p> <p>High Altitude Mode: Set to On when using the projector above an altitude of 1500 m.</p>
Standby Mode	<p>You can use network monitoring and control functions while the projector is in standby mode when this is set to Communication On. (EB-1775W/EB-1770W/EB-1760W only)</p> <p>You can monitor and control the status of the projector over the network by using SNMP, or by using the EasyMP Monitor software.</p> <p> "Useful Software" p.109</p>
USB Type B	<p>Set to USB Display when the projector and a computer are connected by a USB cable and computer images are projected.</p> <p> "Projecting with USB Display" p.28</p> <p>Set to Link 21L to operate the mouse pointer by remote control.</p> <p> "Using the Remote Control to Operate the Mouse Pointer (Wireless Mouse)" p.54</p>
Link 21L	Set to On to use the Link 21L utility software.

Submenu	Function
Projector ID	<p>Set the ID for the projector to a number between 1 and 9. Off indicates that no ID is set.</p> <p> "Setting the Projector ID" p.57</p>
Multi-screen	<p>You can adjust the hue and brightness of each projected image when multiple projectors are lined up and projecting.</p> <p>Adjustment Level: You can adjust from black to white in five stages called Level 1 to 5, and in each of these 5 levels, you can adjust Brightness Correct. and Color Correct.</p> <p>Brightness Correct.: You can correct the difference in the brightness of each projector.</p> <p>Color Correct. (G/R) / Color Correct. (B/Y): You can correct the difference in the color of each projector.</p> <p> "Correcting Color when Projecting from Multiple Projectors" p.58</p>
Language	You can set the language for messages and menus.
Reset	<p>You can reset the adjustment values for Display*1 and Operation*2 from the Extended menu to their default settings.</p> <p>See the following to return all menu items to their default settings.</p> <p> "Reset Menu" p.84</p>

*1 When **User's Logo Protect** is set to **On** in **Password Protect**, settings related to user's logo cannot be changed. You can make changes after setting **User's Logo Protect** to **Off**.

 "Managing Users (Password Protect)" [p.62](#)

*2 Except for High Altitude Mode.

Network Menu (EB-1775W/EB-1770W/EB-1760W Only)

When **Network Protect** is set to **On** in **Password Protect**, a message is displayed and the network settings cannot be changed. Set **Network Protect** to **Off** and then configure the network.

☛ "Setting Password Protect" p.62

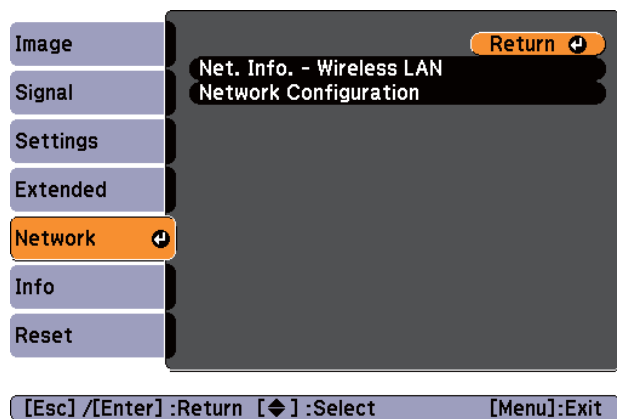

Submenu	Function
Net. Info. - Wireless LAN	Displays the following network setting status information. <ul style="list-style-type: none"> • Connection Mode • Antenna Level • Projector Name • SSID • DHCP • IP Address • Subnet Mask • Gateway Address • MAC Address • Region Code*

Submenu	Function
Network Configuration	The following menus are available for setting Network items. Basic, Wireless LAN, Security, Mail, Others, Reset, and Setup complete

* Displays available region information for the Wireless LAN unit being used. For more details, contact your local dealer or the nearest address provided in the Epson Projector Contact List.

☛ [Epson Projector Contact List](#)



By using the Web browser of a computer connected to the projector on a network, you can set functions and control the projector. This function is called Web Control. You can easily enter text using a keyboard to make settings for Web Control such as security settings.

☛ "Changing Settings Using a Web Browser (Web Control)" p.111

Notes on operating the Network menu

Selecting from the top menu and sub menus, and changing selected items is the same as making operations from the Configuration menu.

When done, make sure you go to the **Setup complete** menu, and select **Yes**, **No**, or **Cancel**. When you select **Yes** or **No**, you are returned to the Configuration menu.



[Esc] : Return [◆] : Select [Enter] : Execute

Yes: Saves the settings and exits the Network menu.

No: Does not save the settings and exits the Network menu.

Cancel: Continues displaying the Network menu.

Soft keyboard operations

The Network menu contains items that require input of alphanumerics during setup. In this case, the following software keyboard is displayed. Use the [↶], [↷], [↵], and [↷] buttons on the remote control or the [↶], [↷], [↵], and [↷] buttons on the control panel to move the cursor to the desired key, and then press the [Enter] button to enter the alphanumeric character. Enter figures by holding down the [Num] button on the remote control, and pressing the numeric buttons. After inputting, press **Finish** on the keyboard to confirm your input. Press **Cancel** on the keyboard to cancel your input.

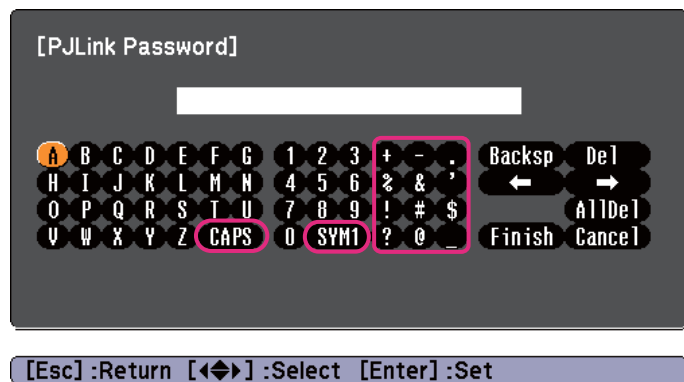

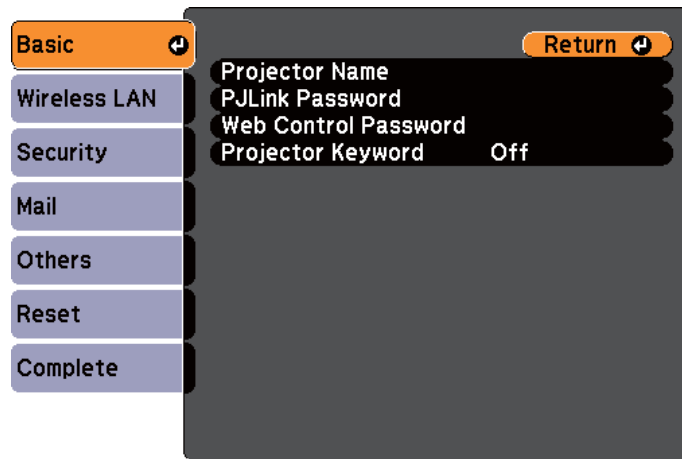

- Each time the **CAPS** key is selected and the [Enter] button is pressed, it sets and changes between upper case and lower case letters.
- Each time the **SYM1/2** key is selected and the [Enter] button is pressed, it sets and changes the symbol keys for the section enclosed by the frame.

Basic menu



[Esc] / [Enter] :Return [◆] :Select

Submenu	Function
Projector Keyword	<p>When set to On, you have to enter the keyword when you try to connect the projector to a computer via a network. As a result, you can prevent presentations from being interrupted by connections from other computers. Normally this should be set to On.</p> <p> EasyMP Network Projection Operation Guide</p>

Submenu	Function
Projector Name	<p>Displays the projector name used to identify the projector when connected to a network.</p> <p>When editing, you can enter up to 16 single-byte alphanumeric characters.</p>
PJLink Password	<p>Set a password to use when you access the projector using compatible PJLink software.</p> <p>You can enter up to 32 single-byte alphanumeric characters.</p>
Web Control Password	<p>Set a password to use when making settings and controlling the projector using Web Control. Enter no more than eight single-byte alphanumeric characters. Web Control is a function that allows you to set up and control the projector by using the Web browser on a computer connected on a network.</p> <p> "Changing Settings Using a Web Browser (Web Control)" p.111</p>

Wireless LAN menu

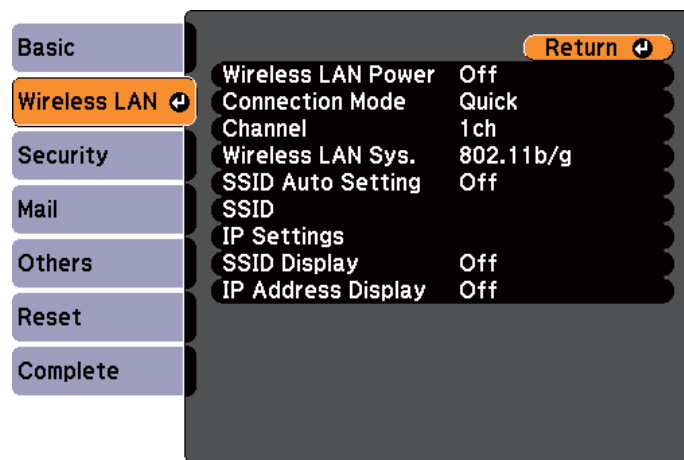

[Esc] / [Enter] : Return [◆] : Select

Submenu	Function
Wireless LAN Power	Turn On when connecting the projector to the computer over wireless LAN. If you do not want to connect via wireless LAN, turn it Off to prevent unauthorized access by others. This is set to On by default.
Connection Mode	Set the connection mode when using EasyMP Network Projection to connect the projector and computer. This is set to Quick by default. See the following manual for details on connection mode. EasyMP Network Projection Operation Guide
Channel	(This can only be set if Connection Mode is set to Quick .) Select the frequency band used by the wireless LAN from 1ch , 6ch , or 11ch . This is set to 11ch by default.

Submenu	Function
Wireless LAN Sys.	Set the Wireless LAN system to either 802.11b/g or 802.11b/g/n . This is set to 802.11b/g by default.
SSID Auto Setting	Set to On to reduce the projector search time when connecting to a network using Quick from Connection Mode . Set to Off when connecting to multiple projectors at the same time. This is set to On by default.
SSID	Enter an SSID . When an SSID is provided for the wireless LAN system in which the projector participates, enter the SSID. You can enter up to 32 single-byte alphanumeric characters.
IP Settings	You can make network settings. DHCP : Set to On to make network settings using DHCP . If this is set to On , you cannot set any more addresses. IP Address : You can input the IP address assigned to the projector. You can enter a number from 0 to 255 in each field of the address. However, the following IP addresses cannot be used. 0.0.0.0, 127.x.x.x, 224.0.0.0 to 255.255.255.255 (where x is a number from 0 to 255) Subnet Mask : You can input the subnet mask for the projector. You can enter a number from 0 to 255 in each field of the address. However, the following subnet masks cannot be used. 0.0.0.0, 255.255.255.255 Gateway Address : You can input the IP address for the gateway for the projector. You can enter a number from 0 to 255 in each field of the address. However, the following gateway addresses cannot be used. 0.0.0.0, 127.x.x.x, 224.0.0.0 to 255.255.255.255 (where x is a number from 0 to 255)
SSID Display	To prevent the SSID from being displayed on the LAN Standby screen, set this to Off .
IP Address Display	To prevent the IP address from being displayed on the LAN Standby screen, set this to Off .

Security menu

Only available when the supplied or optional Wireless LAN unit is installed.



Submenu	Function
Security	Select the security type from the items that are displayed. When setting up Security, follow the instructions from the administrator of the network system you are about to access.
WEP Encryption	You can set the encryption for WEP encryption. 128Bit: Uses 128 (104) bit encoding. 64Bit: Uses 64 (40) bit encoding.
Format	You can set the input method for the WEP encryption key. ASCII: Input text. HEX: Input in HEX (hexadecimal).
Key ID	Selects the WEP encryption ID key.

Submenu	Function
Encryption Key 1/Encryption Key 2/Encryption Key 3/Encryption Key 4	You can enter the key used for WEP encryption. Enter the key in single-byte characters following instructions from the network administrator for the network in which the projector participates. The type and number of characters that can be entered differ depending on the WEP Encryption and Format settings. 128Bit - ASCII: Single-byte alphanumeric, 13 characters. 64Bit - ASCII: Single-byte alphanumeric, 5 characters. 128Bit - HEX: 0 to 9 and A to F, 26 characters 64Bit - HEX: 0 to 9 and A to F, 10 characters
Authentication Type	Set the WEP authentication type. Open: Uses open system authentication. Shared: Uses shared key authentication.
PSK	(This can only be set when WPA-PSK or WPA2-PSK are selected from Security .) You can enter a Pre-Shared Key (encrypted key) in single-byte alphanumeric characters. Enter at least 8 and up to 32 characters.

Type of security

When the supplied or optional wireless LAN unit is installed and being used in Advanced connection mode, it is strongly recommended that you set security. Select one of the following security methods.

- **WEP**

Data is encrypted with a code key (WEP key). This mechanism prevents communication unless the encrypted keys for the access point and the projector match.

- **WPA**

This is an encryption standard that improves security which is a weak point of WEP. Although there are multiple kinds of WPA encryption methods, this projector uses TKIP and AES.

WPA also includes user authentication functions. WPA authentication provides two methods: using an authentication server, or authenticating between a computer and an access point without using a server. This projector supports the latter method, without a server.



For setting details, follow the directions from the network administrator of your network.

Mail menu

When this is set, you receive an email notification if a problem or warning occurs in the projector.

☛ "Using the Mail Notification Function to Report Problems" p.113

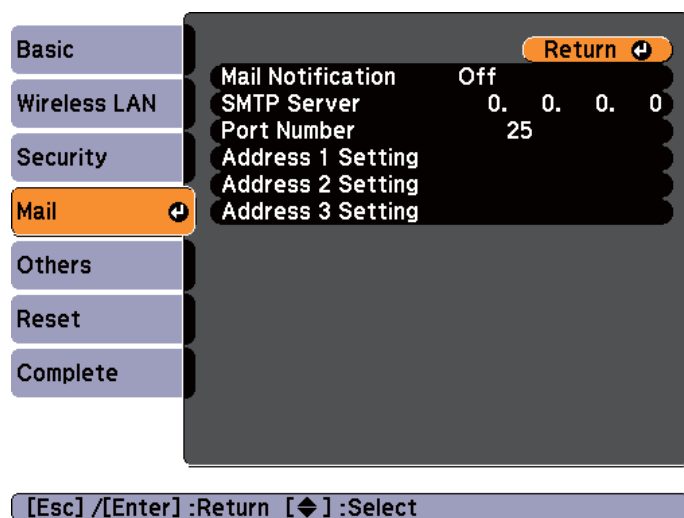

Submenu	Function
Mail Notification	Set to On to send an email to the preset addresses when a problem or warning occurs with a projector.
SMTP Server	You can input the <u>IP address</u> for the SMTP server for the projector. You can enter a number from 0 to 255 in each field of the address. However, the following IP addresses cannot be used. 127.x.x.x, 224.0.0.0 to 255.255.255.255 (where x is a number from 0 to 255)
Port Number	You can input the port number for the SMTP server. The default value is 25. You can input numbers between 1 to 65535.

Submenu	Function
Address 1 Setting, Address 2 Setting, and Address 3 Setting	You can input the email address of the destination to send the notification email to. You can register up to three destinations. You can enter up to 32 single-byte alphanumeric characters for the email addresses. You can select the problems or warnings to be notified about by email. When the selected problem or warning occurs in the projector, an email is sent to the specified destination address notifying that a problem or warning has occurred. You can select multiple items from the displayed items.

Others menu

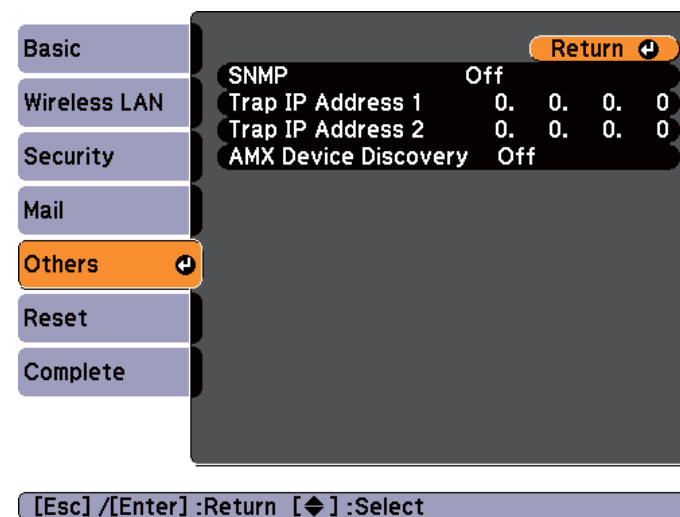

Submenu	Function
SNMP	Set to On to monitor the projector using SNMP. To monitor the projector, you need to install the SNMP manager program on your computer. SNMP should be managed by a network administrator. The default value is Off .

Submenu	Function
Trap IP Address 1/Trap IP Address 2	You can register up to two IP addresses for the SNMP trap notification destination. You can enter a number from 0 to 255 in each field of the address. However, the following IP addresses cannot be used. 127.x.x.x, 224.0.0.0 to 255.255.255.255 (where x is a number from 0 to 255)
AMX Device Discovery	When the projector is connected to a network, set this to On when you want to allow the projector to be detected by <u>AMX Device Discovery</u> . Set this to Off if you are not connected to an environment controlled by a controller from AMX or AMX Device Discovery.

Reset menu

Resets all of the network settings.

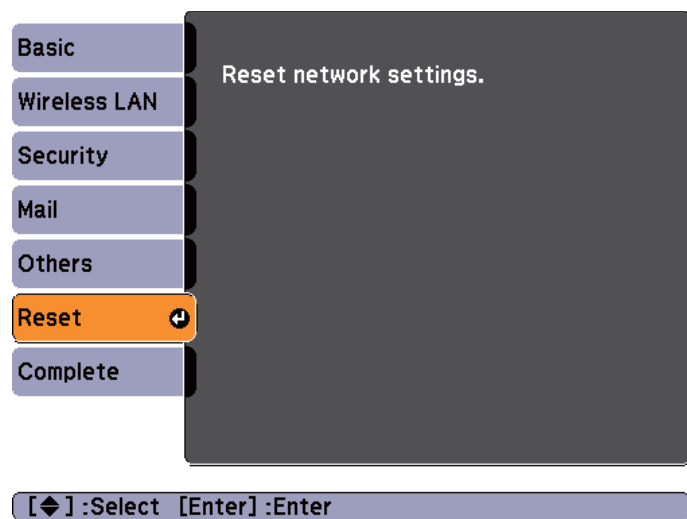

Submenu	Function
Reset network settings.	To reset all of the Network settings, select Yes .

Info Menu (Display Only)

Lets you check the status of the image signals being projected and the status of the projector. Items that can be displayed vary depending on the source currently being projected. Depending on the model used, some input sources are not supported.

☛ "Automatically Detect Input Signals and Change the Projected Image (Source Search)" [p.27](#)

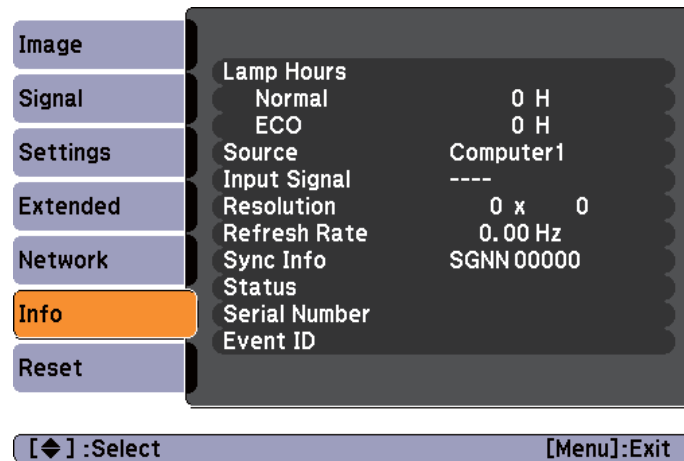

Submenu	Function
Lamp Hours	You can display the cumulative lamp operating time*. When it reaches the lamp warning time, the characters are displayed in yellow.
Source	You can display the source name for the connected equipment currently being projected.
Input Signal	You can display the content of Input Signal set in the Signal menu according to the source.
Resolution	You can display the resolution.

Submenu	Function
Video Signal	You can display the settings for Video Signal in the Signal menu.
Refresh Rate	You can display the <u>refresh rate</u> ▶▶ .
Sync Info	You can display the image signal information. This information may be needed if service is required.
Status	This is information about errors that have occurred on the projector. This information may be needed if service is required.
Serial Number	Displays the projector's serial number.
Event ID (EB-1775W/ EB-1770W/ EB-1760W only)	Displays the application error log. ☛ "About Event ID (EB-1775W/EB-1770W/EB-1760W Only)" p.116

* The cumulative use time is displayed as "0H" for the first 10 hours. 10 hours and above is displayed as "10H", "11H", and so on.

Reset Menu

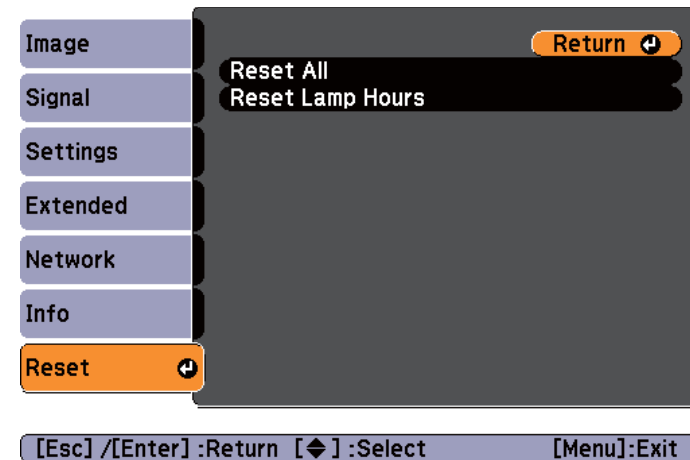

Submenu	Function
Reset All	You can reset all items in the Configuration menu to their default settings. The following items are not reset to their defaults: Input Signal , User's Logo , all items for Network menus*, Lamp Hours , Language , Password , User Button , and Multi-screen .
Reset Lamp Hours	Clears the cumulative lamp hours use time. Reset when you replace the lamp.

* (EB-1775W/EB-1770W/EB-1760W only)



Troubleshooting

This chapter explains how to identify problems and what to do if a problem is found.

If a problem occurs with the projector, the Help screen is displayed to assist you by pressing the Help button. You can solve problems by answering the questions.

- 1 Press the [Help] button.
The Help screen is displayed.

Using the remote control

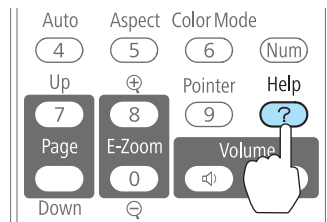

Using the control panel

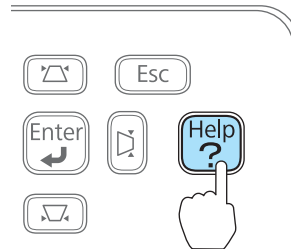

- 2 Select a menu item.

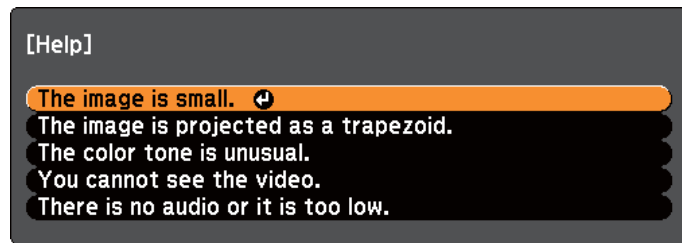

Using the remote control

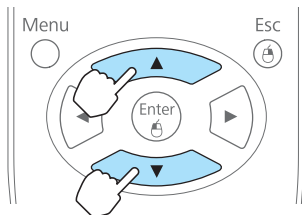

Using the control panel

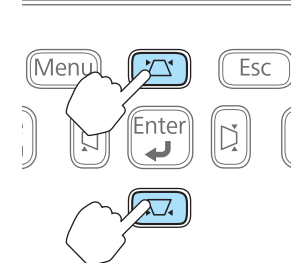

- 3 Confirm the selection.

Using the remote control

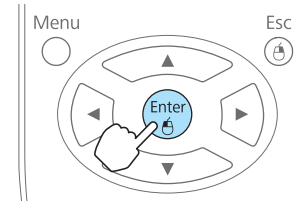

Using the control panel



Questions and solutions are displayed as shown on the screen below. Press the [Help] button to exit the Help.

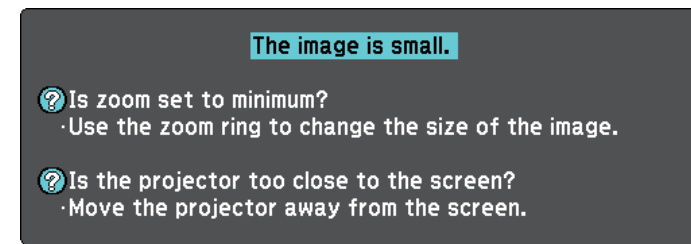

See the following if the Help function does not provide a solution to the problem.

☞ "Problem Solving" p.88

If you are having a problem with the projector, first check the projector's indicators and refer to "Reading the Indicators" below. See the following if the indicators do not show clearly what the problem might be.

☛ "When the Indicators Provide No Help" [p.91](#)



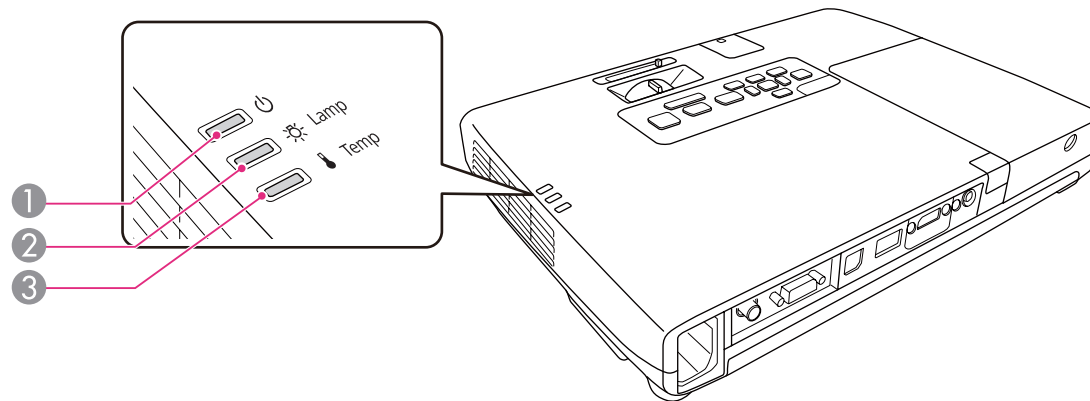

Reading the Indicators

The projector is provided with the following three indicators that indicate the operating status of the projector.



① Power indicator

Indicates the operating status.

-  Standby condition
When the [⏻] button is pressed in this condition, projection starts.
-  Preparing for network monitoring or cool down in progress
All buttons are disabled while the indicator is flashing.
-  Warming up
Warm-up time is about 30 seconds. After warm-up is complete, the indicator stops flashing.
The [⏻] button is disabled during warm-up.
-  Projecting

② Lamp indicator

Indicates the projection lamp status.





③ Temp indicator



















Indicates the internal temperature status.



Refer to the following table to see what the indicators mean and how to remedy problems that they indicate.

If all indicators are off, check that the power cable is connected correctly and that the power is being supplied normally.

Sometimes, when the power cable is unplugged, the  indicator remains lit for a short period, but this is not a fault.

 : Lit  : Flashing  : Off  : Varies according to the projector status

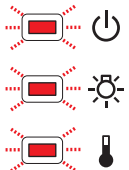
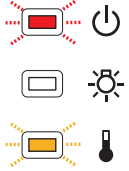
Status	Cause	Remedy or Status
  	Internal Error	Stop using the projector, remove the power plug from the electrical outlet, and contact your local dealer or the nearest address provided in the <i>Epson Projector Contact List</i> .  Epson Projector Contact List
  	Fan Error Sensor Error	Stop using the projector, remove the power plug from the electrical outlet, and contact your local dealer or the nearest address provided in the <i>Epson Projector Contact List</i> .  Epson Projector Contact List
  	High Temp Error (overheating)	The lamp turns off automatically and projection stops. Wait for about five minutes. After about five minutes the projector switches to standby mode, so check the following two points. <ul style="list-style-type: none"> • Check that the air filter and air exhaust vent are clear, and that the projector is not positioned against a wall. • If the air filter is clogged, clean or replace it.  "Cleaning the Air Filter" p.101, "Replacing the Air Filter" p.106 If the error continues after checking the points above, stop using the projector, remove the power plug from the electrical outlet, and contact your local dealer or the nearest address provided in the <i>Epson Projector Contact List</i> .  Epson Projector Contact List
		When using at an altitude of 1500 m or more, set High Altitude Mode to On .  "Extended Menu" p.74
  	Lamp Error Lamp Failure	Check the following two points. <ul style="list-style-type: none"> • Take out the lamp and check if it is cracked.  "Replacing the Lamp" p.103 • Clean the air filter.  "Cleaning the Air Filter" p.101

Status	Cause	Remedy or Status
		<p>If it is not cracked: Reinstall the lamp and turn on the power.</p> <p>If the error continues: Replace the lamp with a new one and then turn on the power.</p> <p>If the error continues: Stop using the projector, remove the power plug from the electrical outlet, and contact your local dealer or the nearest address provided in the <i>Epson Projector Contact List</i>.</p> <p>☞ Epson Projector Contact List</p>
		<p>If it is cracked: Contact your local dealer or the nearest address provided in the <i>Epson Projector Contact List</i>. (Images cannot be projected until the lamp is replaced.)</p> <p>☞ Epson Projector Contact List</p>
		<p>When using at an altitude of 1500 m or more, set High Altitude Mode to On.</p> <p>☞ "Extended Menu" p.74</p>
	Auto Iris Error Power Err. (Ballast)	<p>Stop using the projector, remove the power plug from the electrical outlet, and contact your local dealer or the nearest address provided in the <i>Epson Projector Contact List</i>.</p> <p>☞ Epson Projector Contact List</p>
	High Temp Warning	<p>(This is not an abnormality. However, if the temperature rises too high again, projection stops automatically.)</p> <ul style="list-style-type: none"> • Check that the air filter and air exhaust vent are clear, and that the projector is not positioned against a wall. • If the air filter is clogged, clean or replace it. <ul style="list-style-type: none"> ☞ "Cleaning the Air Filter" p.101, "Replacing the Air Filter" p.106
	Replace Lamp	<p>Replace it with a new lamp.</p> <p>☞ "Replacing the Lamp" p.103</p> <p>If you continue to use the lamp after the replacement period has passed, the possibility that the lamp may explode increases. Replace it with a new lamp as soon as possible.</p>











- See the following if the projector is not operating properly, even though the indicators are all showing normal.
 - ☞ "When the Indicators Provide No Help" [p.91](#)
- If the indicators are in a state not shown in this table, stop using the projector, remove the power plug from the electrical outlet, and contact your local dealer or the nearest address provided in the *Epson Projector Contact List*.
 - ☞ [Epson Projector Contact List](#)

When the Indicators Provide No Help

If any of the following problems occur and the indicators do not offer a solution, refer to the pages given for each problem.



Problems Relating to Images



<ul style="list-style-type: none"> • No images appear Projection does not start, the projection area is completely black, or the projection area is completely blue. 	 p.92
<ul style="list-style-type: none"> • Moving images are not displayed Moving images being projected from a computer appear black and nothing is projected. 	 p.93
<ul style="list-style-type: none"> • Projection stops automatically 	 p.93
<ul style="list-style-type: none"> • The message "Not supported" is displayed 	 p.93
<ul style="list-style-type: none"> • The message "No Signal" is displayed 	 p.93
<ul style="list-style-type: none"> • Interference or distortion appear in images 	 p.95
<ul style="list-style-type: none"> • The image is truncated (large) or small, or the aspect ratio is not suitable Only part of the image is displayed, or the height and width ratios of the image are not correct. 	 p.95
<ul style="list-style-type: none"> • Image colors are not right The whole image appears purplish or greenish, images are black & white, or colors appear dull. 	 p.96
<ul style="list-style-type: none"> • Images appear dark 	 p.97

Problems when projection starts

<ul style="list-style-type: none"> • The projector does not turn on 	 p.97
---	--

Other Problems

<ul style="list-style-type: none"> • No sound can be heard or the sound is faint 	 p.98
<ul style="list-style-type: none"> • The remote control does not work 	 p.98

<ul style="list-style-type: none"> • I want to change the language for messages and menus 	 p.99
<ul style="list-style-type: none"> • Email is not received even if a problem occurs in the projector (EB-1775W/EB-1770W/EB-1760W only) 	 p.99

Problems Relating to Images

No images appear

Check	Remedy
Did you press the [⏻] button?	Press the [⏻] button to turn the power on.
Are the indicators switched off?	The power cable is not connected correctly or power is not being supplied. Connect the projector's power cable correctly. 🖱️ "From Installation to Projection" p.26 Check that your electrical outlet or power source is functioning correctly.
Is A/V Mute active?	Press the [A/V Mute] button on the remote control to cancel A/V Mute. 🖱️ "Hiding the Image and Sound Temporarily (A/V Mute)" p.51
Is the A/V mute slide closed?	Open the A/V mute slide. 🖱️ "Front/Top" p.10
Are the Configuration menu settings correct?	Reset all of the settings. 🖱️ Reset - Reset All p.84 When using USB Display, set USB Type B to USB Display . 🖱️ Extended - USB Type B p.74
Is the image to be projected completely black? (Only when projecting computer images)	Some input images, such as screen savers, may be completely black.
Is the image signal format setting correct? (Only when projecting images from a video source)	Change the setting according to the signal for the connected equipment. 🖱️ Signal - Video Signal p.71
Is the USB cable connected correctly? (Only when projecting using USB Display)	Check that the USB cable is connected correctly. Reconnect it if it is not connected or not connected properly.
Is Windows Media Center displayed in full screen? (Only when projecting using USB Display or network connection)	When Windows Media Center is displayed at full screen, you cannot project using USB Display or network connection. Reduce the screen size.
Is an application using the Windows DirectX function displayed? (Only when projecting using USB Display or network connection)	Applications using the Windows DirectX function may not display images correctly.

Moving images are not displayed (only the moving image portion turns black)

Check	Remedy
Is the computer's image signal being output to the LCD and the monitor? (Only when projecting images from a laptop computer or a computer with a built-in LCD screen)	Change the image signal from the computer to external output only. Check your computer's documentation, or contact the computer's manufacturer.

Projection stops automatically

Check	Remedy
Is Sleep Mode set to On ?	Press the [⏻] button to turn the power on. If you do not want to use Sleep Mode, change the setting to Off . 🖱️ Extended - Operation - Sleep Mode p.74

The message "Not supported" is displayed

Check	Remedy
Is the image signal format setting correct? (Only when projecting images from a video source)	Change the setting according to the signal for the connected equipment. 🖱️ Signal - Video Signal p.71
Do the image signal resolution and the refresh rate correspond to the mode? (Only when projecting computer images)	Refer to the computer's documentation for how to change the image signal resolution and the refresh rate output from the computer. 🖱️ "Supported Monitor Displays" p.121

The message "No Signal" is displayed

Check	Remedy
Are the cables connected correctly?	Check that all the cables required for projection are securely connected. 🖱️ "From Installation to Projection" p.26
Is the correct port selected?	Change the image by pressing the [Source Search] button on the remote control or the control panel. 🖱️ "Automatically Detect Input Signals and Change the Projected Image (Source Search)" p.27
Is the power for the computer or video source turned on?	Turn the power on for the equipment.

Check	Remedy
<p>Are the image signals being output to the projector? (Only when projecting images from a laptop computer or a computer with a built-in LCD screen)</p>	<p>If the image signals are only being output to the computer's LCD monitor or to the accessory monitor, you need to change the output to an external destination as well as the computer's own monitor. For some computer models, when the image signals are output externally, they no longer appear on the LCD monitor or accessory monitor.</p> <p>If the connection is made while the power of the projector or computer is already turned on, the Fn key (Function key) that changes the computer's image signal to external output may not work. Turn the power for the computer and the projector off and then back on again.</p> <ul style="list-style-type: none"> ☛ "From Installation to Projection" p.26 ☛ Computer's documentation

Images are fuzzy, out of focus, or distorted

Check	Remedy
<p>Is the distance between the projector and the screen over 2.5 m? (For EB-1775W)</p>	<p>For the projected image to be automatically adjusted by Auto H/V-Keystone or Screen Fit, the projector cannot be more than approximately 1.0 to 2.5 m away from the screen. If the projector must be placed further away than this, manually adjust the projected image.</p>
<p>Is Auto H/V-Keystone set to Off? (EB-1775W only)</p>	<p>Setting it to On enables Auto H/V-Keystone.</p> <ul style="list-style-type: none"> ☛ Settings - Keystone - Auto H/V-Keystone p.73 <p>If you are using the projector with this setting off, manually adjust the projected image.</p> <ul style="list-style-type: none"> ☛ "Correcting manually - manual H/V-Keystone -" p.34
<p>Is the focus adjusted correctly?</p>	<p>Adjust the focus using the [Focus] buttons (EB-1775W only) or Focus ring (EB-1770W/EB-1760W/EB-1750 only).</p> <ul style="list-style-type: none"> ☛ "Correcting the Focus" p.37
<p>Is the projector at the correct distance?</p>	<p>Is it projecting outside of the recommended projection distance range? Setup within the recommended range.</p> <ul style="list-style-type: none"> ☛ "Screen Size and Projection Distance" p.118
<p>Is the keystone adjustment value too large?</p>	<p>Lower the projection angle to reduce the amount of keystone correction.</p> <ul style="list-style-type: none"> ☛ "Adjusting the Image Position" p.37
<p>Has condensation formed on the lens?</p>	<p>If the projector is suddenly taken from a cold environment to a warm environment, or if sudden ambient temperature changes occur, condensation may form on the surface of the lens, and this may cause the images to appear fuzzy. Set the projector up in the room about one hour before it is used. If condensation forms on the lens, turn the projector off and wait for the condensation to disappear.</p>

Interference or distortion appear in images

Check	Remedy
Is the image signal format setting correct? (Only when projecting images from a video source)	Change the setting according to the signal for the connected equipment. ☛ Signal - Video Signal p.71
Are the cables connected correctly?	Check that all the cables required for projection are securely connected. ☛ "Connecting Equipment" p.21
Is an extension cable being used?	If an extension cable is used, electrical interference may affect the signals. Use the cables supplied with the projector to check if the cables you are using may be causing the problem.
Is the correct resolution selected? (Only when projecting computer images)	Set the computer so that the signals being output are compatible with the projector. ☛ "Supported Monitor Displays" p.121 ☛ Computer's documentation
Are the Sync and Tracking settings adjusted correctly? (Only when projecting computer images)	Press the [Auto] button on the remote control or the [Enter] button on the control panel to perform automatic adjustment. If the images are not adjusted correctly even after performing automatic adjustment, you can also make adjustments from the Configuration menu. ☛ Signal - Tracking, Sync. p.71
Is Transfer layered window selected? (Only when projecting using USB Display)	Click All Programs - EPSON Projector - EPSON USB Display - EPSON USB Display Vx.xx Settings , and then clear the Transfer layered window checkbox.

The image is truncated (large) or small, or the aspect is not suitable

Check	Remedy
Is a wide panel computer image being projected? (Only when projecting computer images)	Change the setting according to the signal for the connected equipment. ☛ Signal - Resolution p.71
Is the image still being enlarged by E-Zoom?	Press the [Esc] button on the remote control to cancel E-Zoom. ☛ "Enlarging Part of the Image (E-Zoom)" p.53
Is the image position adjusted correctly?	Press the [Auto] button on the remote control or the [Enter] button on the control panel to perform automatic adjustment of the computer image being projected. If the images are not adjusted correctly even after performing automatic adjustment, you can also make adjustments from the Configuration menu. Apart from computer image signals, you can adjust other signals while projecting from the Configuration menu. ☛ Signal - Position p.71

Check	Remedy
Is the computer set for dual display? (Only when projecting computer images)	If dual display is activated in the Display Properties of the computer's Control Panel, only about half of the image on the computer screen is projected. To display the entire image on the computer screen, turn off the dual display setting. ☛ Computer video driver documentation
Is the correct resolution selected? (Only when projecting computer images)	Set the computer so that the signals being output are compatible with the projector. ☛ "Supported Monitor Displays" p.121 ☛ Computer's documentation

Image colors are not right

Check	Remedy
Do the input signal settings match the signals from the connected device?	Change the following settings according to the signal for the connected equipment. <ul style="list-style-type: none"> • When image is from a device connected to the Computer port ☛ Signal - Input Signal p.71 • When image is from a device connected to the Video port ☛ Signal - Video Signal p.71
Is the image brightness adjusted correctly?	Adjust the Brightness setting from the Configuration menu. ☛ Image - Brightness p.70
Are the cables connected correctly?	Check that all the cables required for projection are securely connected. ☛ "Connecting Equipment" p.21
Is the <u>contrast</u>  adjusted correctly?	Adjust the Contrast setting from the Configuration menu. ☛ Image - Contrast p.70
Is the color adjustment set correctly?	Adjust the Color Adjustment setting from the Configuration menu. ☛ Image - Color Adjustment p.70
Are the color saturation and tint adjusted correctly? (Only when projecting images from a video source)	Adjust the Color Saturation and Tint settings from the Configuration menu. ☛ Image - Color Saturation, Tint p.70

Images appear dark

Check	Remedy
Is the image brightness set correctly?	Adjust the Brightness and Power Consumption settings from the Configuration menu. ☛ Image - Brightness p.70 ☛ Settings - Power Consumption p.73
Is the <u>contrast</u> adjusted correctly?	Adjust the Contrast setting from the Configuration menu. ☛ Image - Contrast p.70
Is it time to replace the lamp?	When the lamp is nearly ready for replacement, the images become darker and the color quality becomes poorer. When this happens, replace the lamp with a new lamp. ☛ "Replacing the Lamp" p.103



Problems when Projection Starts

The projector does not turn on





Check	Remedy
Did you press the [⏻] button?	Press the [⏻] button to turn the power on.
Are the indicators switched off?	The power cable is not connected correctly or power is not being supplied. Disconnect and then reconnect the power cable. ☛ "From Installation to Projection" p.26 Check that your electrical outlet or power source is functioning correctly.
Do the indicators turn on and off when the power cable is touched?	There is probably a poor contact in the power cable, or the power cable may be defective. Reinsert the power cable. If this does not solve the problem, stop using the projector, disconnect the power cable from the electrical outlet, and contact your local dealer or the nearest address provided in the <i>Epson Projector Contact List</i> . ☛ Epson Projector Contact List
Is the Control Panel Lock set to Full Lock ?	Press the [⏻] button on the remote control. If you do not want to use Control Panel Lock , change the setting to Off . ☛ Settings - Control Panel Lock p.73
Is the correct setting for the remote receiver selected?	Check the Remote Receiver from the Configuration menu. ☛ Settings - Remote Receiver p.73

Other Problems

No sound can be heard or the sound is faint

Check	Remedy
Check that the audio/video cable is securely attached to both the projector and audio source.	Disconnect the cable from the Audio port, and then reconnect the cable.
Is the volume adjusted to the minimum setting?	Adjust the volume so that sound can be heard.  Settings - Volume p.73  "Adjusting the Volume" p.38
Is A/V Mute active?	Press the [A/V Mute] button on the remote control to cancel A/V Mute.  "Hiding the Image and Sound Temporarily (A/V Mute)" p.51
Is the audio cable's specification "No resistance"?	When using a commercially available audio cable, make sure it is labeled "No resistance".
Is it connected with an HDMI cable? (EB-1775W/EB-1770W/EB-1760W only)	If no audio is output when connecting via an HDMI cable, set the connected equipment to PCM output.
Is Output audio from the projector selected? (Only when projecting using USB Display)	Click All Programs - EPSON Projector - EPSON USB Display - EPSON USB Display Vx.xx Settings , and then select Output audio from the projector .

The remote control does not work

Check	Remedy
Is the remote control light-emitting area pointing towards the remote receiver on the projector during operation?	Point the remote control towards the remote receiver.  "Remote control operating range" p.17
Is the remote control too far from the projector?	The operating range for the remote control is about 6 m.  "Remote control operating range" p.17
Is direct sunlight or strong light from fluorescent lamps shining onto the remote receiver?	Set the projector up in a location where strong light does not shine onto the remote receiver. Or set the remote receiver to Off from Remote Receiver in the Configuration menu.  Settings - Remote Receiver p.73
Is the correct setting for the Remote Receiver selected?	Check the Remote Receiver from the Configuration menu.  Settings - Remote Receiver p.73

Check	Remedy
Are the batteries dead or have the batteries been inserted correctly?	Make sure the batteries are inserted correctly or replace the batteries with new ones if necessary. ☛ "Replacing the remote control batteries" p.17
Are the remote control ID and the projector ID matched?	Make sure the ID for the projector you want to operate and the ID for the remote control match. To operate all projectors by remote control regardless of the ID setting, set the remote control ID to "0". ☛ "Setting the remote control ID" p.57

I want to change the language for messages and menus

Check	Remedy
Change the Language setting.	Adjust the Language setting from the Configuration menu. ☛ Extended - Language p.74

Email is not received even if a problem occurs in the projector (EB-1775W/EB-1770W/EB-1760W only)

Check	Remedy
Is Standby Mode set to Communication On ?	To use the Mail Notification function when the projector is in standby, set Communication On in Standby Mode from the Configuration menu. ☛ Extended - Standby Mode p.74
Did a fatal abnormality occur and the projector come to a sudden stop?	When the projector comes to a sudden stop, email cannot be sent. If the abnormal state continues, contact your local dealer or the nearest address provided in the <i>Epson Projector Contact List</i> . ☛ Epson Projector Contact List
Is power being supplied to the projector?	Check that your electrical outlet or power source is functioning correctly.
Is Mail Notification function set correctly in the Configuration menu?	An error notification email is sent according to the Mail settings in the Configuration menu. Check if it is set correctly. ☛ "Mail menu" p.82



Maintenance

This chapter provides information on maintenance procedures to ensure the best level of performance from the projector for a long time to come.

You should clean the projector if it becomes dirty or if the quality of projected images starts to deteriorate.

Attention

Turn off the projector's power before cleaning.

Cleaning the Projector's Surface

Clean the projector's surface by wiping it gently with a soft cloth.

If the projector is particularly dirty, moisten the cloth with water containing a small amount of neutral detergent, and then firmly wring the cloth dry before using it to wipe the projector's surface.

Attention

Do not use volatile substances such as wax, alcohol, or thinner to clean the projector's surface. The quality of the case may change or become discolored.

Cleaning the Lens

Use a commercially available cloth for cleaning glasses to gently wipe the lens.

Warning

Do not use sprays that contain flammable gas to remove dust and lint from the lens. The projector may catch fire due to the high internal temperature of the lamp.

Attention

Do not rub the lens with harsh materials or subject the lens to shocks, as it can easily become damaged.

Cleaning the Air Filter

Clean the air filter and the air intake vent when the following message is displayed.

"The projector is overheating. Make sure nothing is blocking the air vent, and clean or replace the air filter."

Attention

- If dust collects on the air filter it can cause the internal temperature of the projector to rise, and this can lead to problems with operation and shorten the optical engine's service life. Clean the air filter immediately when the message is displayed.
- Do not rinse the air filter in water. Do not use detergents or solvents.

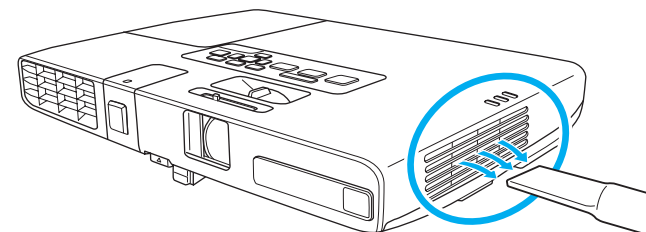



- If a message is frequently displayed, even after cleaning, it is time to replace the air filter. Replace it with a new air filter.
 - ☛ "Replacing the Air Filter" [p.106](#)
- It is recommended that you clean these parts at least once every three months. Clean them more often than this if using the projector in a particularly dusty environment.

This section explains how to replace the lamp and the air filter.

Replacing the Lamp

Lamp replacement period

It is time to replace the lamp when:

- The message "Replace the lamp." is displayed at the lower left of the projection screen when you start projecting.



The message is displayed for 30 seconds.

- The lamp indicator flashes orange.

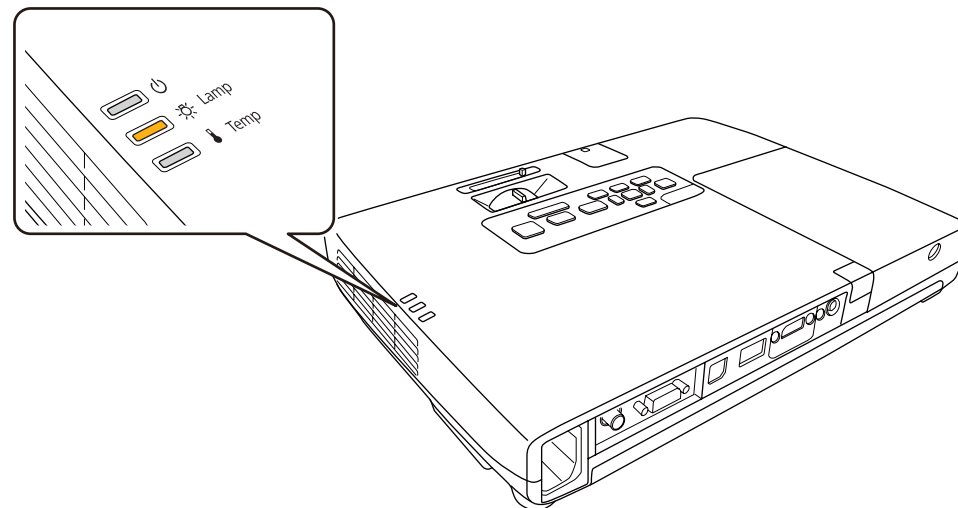

- The projected image gets darker or starts to deteriorate.

Attention

- The lamp replacement message is set to appear after the following time periods in order to maintain the initial brightness and quality of the projected images.

Lamp operating life: about 3900 hours

- If you continue to use the lamp after the replacement period has passed, the possibility that the lamp may explode increases. When the lamp replacement message appears, replace the lamp with a new one as soon as possible, even if it is still working.
- Do not repeatedly turn off the power and immediately back on. Turning the power on and off frequently may shorten the lamp's operating life.
- Depending on the characteristics of the lamp and the way it has been used, the lamp may become darker or stop working before the lamp warning message appears. You should always have a spare lamp unit ready in case it is needed.

How to replace the lamp

The lamp can be replaced even when the projector is suspended from a ceiling.

Warning

- When replacing the lamp because it has stopped illuminating, there is a possibility that the lamp may be broken. If replacing the lamp of a projector which has been installed on the ceiling, you should always assume that the lamp is cracked, and you should stand to the side of the lamp cover, not underneath it. Remove the lamp cover gently.
- Never disassemble or remodel the lamp. If a modified or disassembled lamp is installed in the projector and used, it could cause a fire, electric shock, or an accident.

Caution

Wait until the lamp has cooled down sufficiently before removing the lamp cover. If the lamp is still hot, burns or other injuries may result. It takes about one hour after the power has been turned off for the lamp to be cool enough.

- 1** After you turn off the projector's power and the confirmation buzzer beeps twice, disconnect the power cable.
- 2** Wait until the lamp has sufficiently cooled down, and then remove the lamp cover at the top of the projector.
Loosen the lamp cover fixing screw with the screwdriver supplied with the new lamp unit or a + head screwdriver.

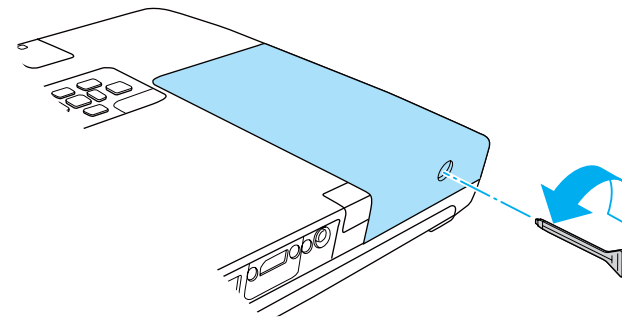

Then slide the lamp cover straight forward and lift it to remove.

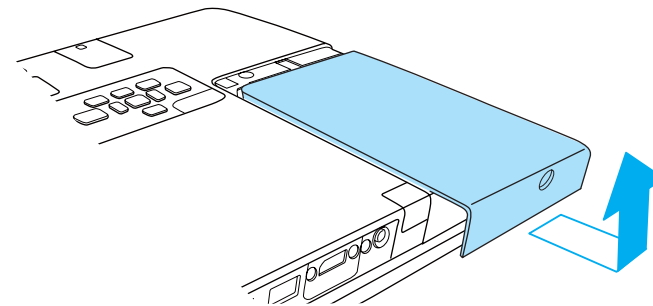

- 3** Raise the lamp fixing spring.

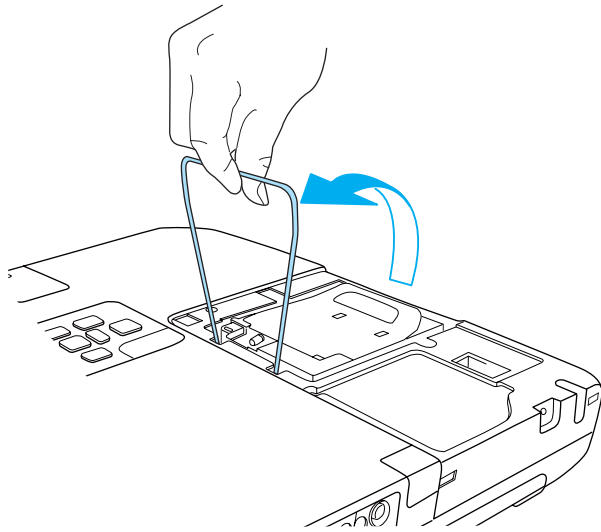

- 4** Raise the handle and take out the old lamp.
If the lamp is cracked, contact your local dealer or the nearest address provided in the *Epson Projector Contact List*.

☛ [Epson Projector Contact List](#)

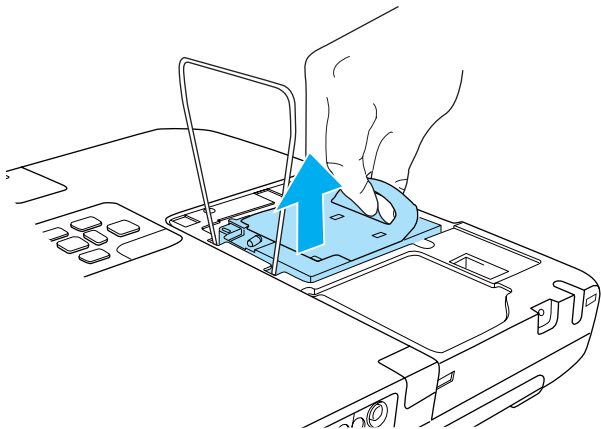

- 5** Install the new lamp.
Insert the new lamp along the guide rails in the correct direction so that it fits, and push it firmly into place. Press down on the part marked PUSH to fix the lamp in place.

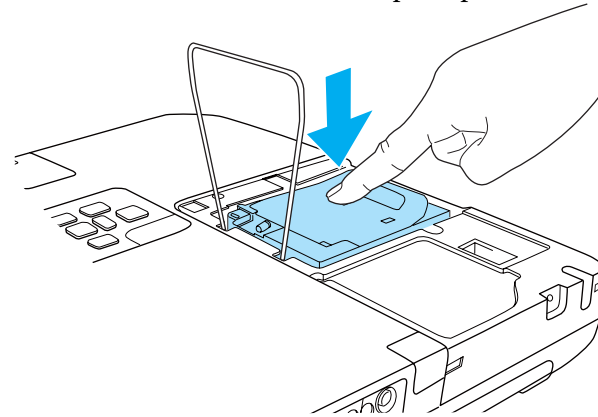

- 6** Lower the lamp fixing spring, and press down on the left and right until it clicks into place.

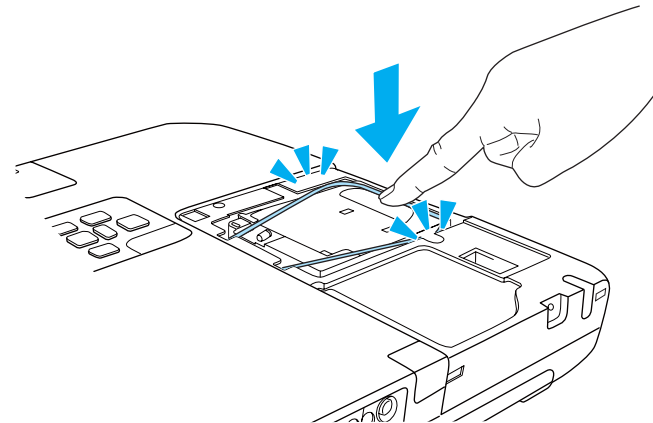

- 7** Replace the lamp cover.
Insert the hook as shown in the illustration below, and attach the cover. Tighten the lamp cover fixing screw.

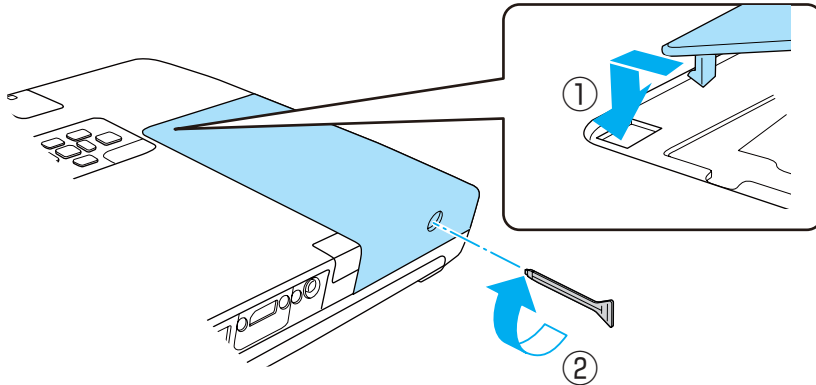

Attention

- Make sure you install the lamp securely. If the lamp cover is removed, the power turns off automatically as a safety precaution. If the lamp or the lamp cover is not installed correctly, the power does not turn on.
- This product includes a lamp component that contains mercury (Hg). Please consult your local regulations regarding disposal or recycling. Do not dispose of it with normal waste.

Resetting the lamp hours

The projector records how long the lamp is turned on and a message and indicator notify you when it is time to replace the lamp. After replacing the lamp, make sure you reset the **Lamp Hours** from the Configuration menu.

☛ "Reset Menu" [p.84](#)



Only reset the **Lamp Hours** after the lamp has been replaced. Otherwise the lamp replacement period is not indicated correctly.

Replacing the Air Filter

Air filter replacement period

It is time to replace the air filter when:

- There is a tear in the air filter.
- The message is displayed even though the air filter has been cleaned.

How to replace the air filter

The air filter can be replaced even when the projector is suspended from a ceiling.

- 1** After you turn off the projector's power and the confirmation buzzer beeps twice, disconnect the power cable.
- 2** Remove the air filter.
Grip the tab in the center of the air filter, and pull it straight out.

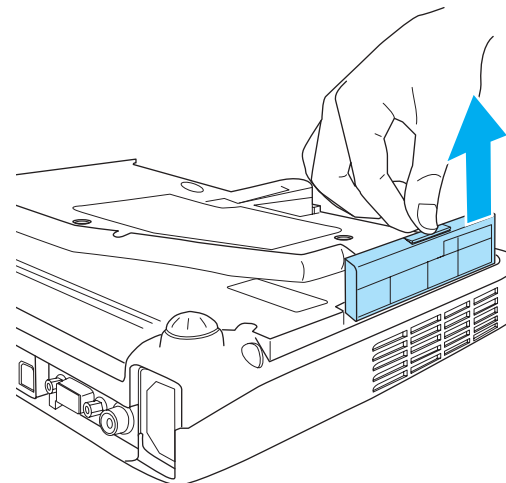

- 3** Install the new air filter.
Push in the air filter until it clicks into place.

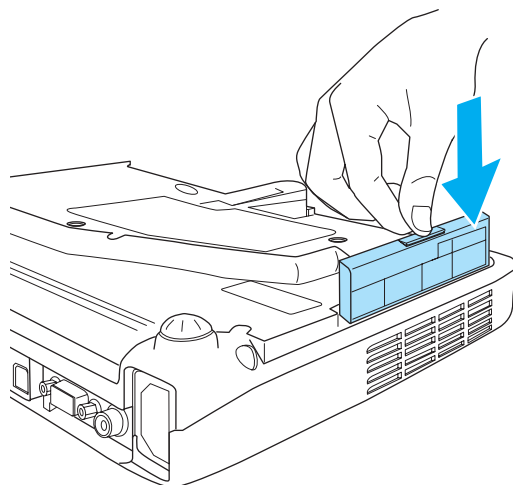

Dispose of used air filters properly in accordance with your local regulations.

Material of the frame part: Polyphenylene ether and polystyrene resin

Material of the filter part: Polyurethane foam



Appendix

EasyMP Network Projection (EB-1775W/EB-1770W/EB-1760W only)

By using the supplied EasyMP Network Projection, you can project your computer screen from the projector via a network. Sharing the projector over the network allows you to project data from different computers without changing the signal cable. Even if the projector is away from the computer, you can still project data via a network. You can also output the computer's audio from the projector.

This projector only supports network projection using a wireless LAN connection.

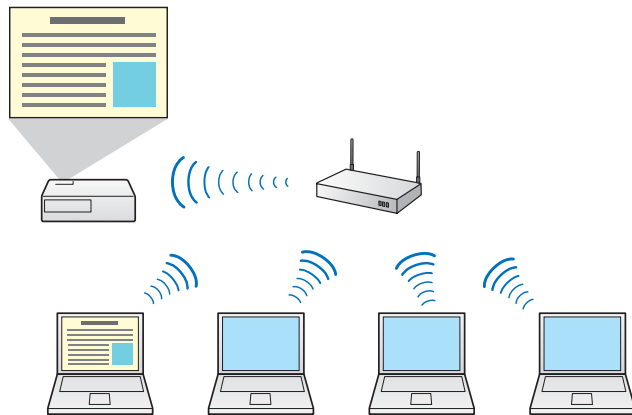

See the following for more details.

☛ [EasyMP Network Projection Operation Guide](#)

EasyMP Slide Converter

By using the supplied EasyMP Slide Converter, you can convert PowerPoint files to scenarios that can be played directly from the projector.

Save the converted scenario to a USB storage device. When the USB storage device is connected to the projector, Slideshow starts.

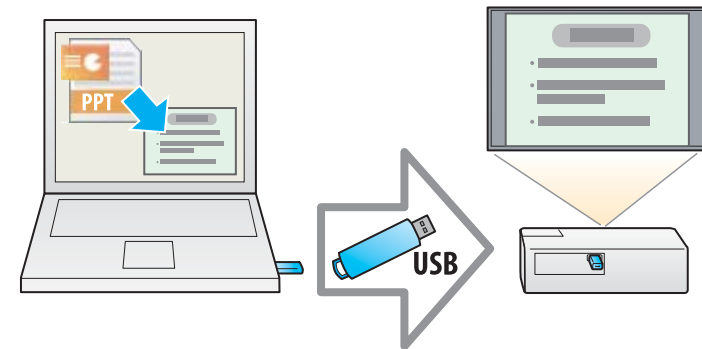

See the following for more details.

☛ [EasyMP Slide Converter Operation Guide](#)

☛ "Slideshow operating methods" p.46

EasyMP Monitor (EB-1775W/EB-1770W/EB-1760W only)

By using EasyMP Monitor, you can check the status of multiple Epson projectors on the network, and you can control them from your computer.

You can download EasyMP Monitor from the following Web site.

<http://www.epson.com>

The following optional accessories and consumables are available. Please purchase these products as and when needed. The following list of optional accessories and consumables is current as of: August 2010. Details of accessories are subject to change without notice and availability may vary depending on the country of purchase.

Optional Accessories

50" portable screen ELPSC06

A compact screen that can be carried easily. ([aspect ratio](#) ▶▶ 4:3)

60" portable screen ELPSC27

80" portable screen ELPSC28

100" screen ELPSC29

Portable roll-type screens. (aspect ratio 4:3)

53" portable screen ELPSC30

64" portable screen ELPSC31

Portable magnetic screens. (aspect ratio 4:3)

Computer cable ELPKC02

(1.8 m - for mini D-Sub15-pin/mini D-Sub 15pin)

This is the same as the computer cable supplied with the projector.

Computer cable ELPKC09

(3 m - for mini D-Sub15-pin/mini D-Sub 15pin)

Computer cable ELPKC10

(20 m - for mini D-Sub15-pin/mini D-Sub 15pin)

Use one of these longer cables if the computer cable supplied with the projector is too short.

Component video cable ELPKC19

(3 m - for mini D-Sub 15-pin/RCA male×3)

Use to connect a [component video](#) ▶▶ source.

Document camera ELPDC06

Use when projecting images such as books, OHP documents, or slides.

Wireless LAN unit ELPAP07 (EB-1770W/EB-1760W only)

Use when connecting the projector to a computer wirelessly and projecting.

Quick Wireless Connection USB Key ELPAP08 (EB-1775W/EB-1770W/EB-1760W only)

Use when you want to quickly establish one-to-one connection between the projector and a computer with Windows installed.

Ceiling pipe (450 mm)* ELPFP13

Ceiling pipe (700 mm)* ELPFP14

Use when installing the projector on a high ceiling.

Ceiling mount* ELPMB23

Use when installing the projector on a ceiling.

Attachment plate* ELPPT01

Use when attaching the ceiling mount to the projector.

* Special expertise is required to suspend the projector from a ceiling. Contact your local dealer or the nearest address provided in the *Epson Projector Contact List*.

👉 [Epson Projector Contact List](#)

Consumables

Lamp unit ELPLP65

Use as a replacement for used lamps.

Air filter ELPAF31

Use as a replacement for used air filters.

Changing Settings Using a Web Browser (Web Control)

By using the Web browser of a computer connected to the projector on a network, you can make settings and control the projector. This function allows you to perform setup and control operations remotely. In addition, since you can use the computer's keyboard, entering characters required for the setup is easier.

Use Microsoft Internet Explorer 6.0 or later as the Web browser. You can also use Safari if you are using Mac OS.



If you set **Standby Mode** to **Communication On**, you can use the Web browser to make settings and perform control even if the projector is in standby mode (when the power is off).

☛ **Extended - Standby Mode** p.74

Projector setup

In the Web browser, you can set items that are usually set in the projector's Configuration menu. The settings are reflected in the Configuration menu. There are also items that can only be set in the Web browser.

Items in the Configuration menu that cannot be set by the Web browser

- Settings Menu - Pointer Shape
- Settings Menu - Test Pattern
- Settings Menu - User Button
- Extended Menu - User's Logo
- Extended Menu - Language
- Extended Menu - Operation - High Altitude Mode
- Extended Menu - Operation - Lens Cover Timer
- Reset Menu - Reset All and Reset Lamp Hours

The settings for items on each menu are the same as the projector's Configuration menu.

☛ "Configuration Menu" p.66

Items that can only be set with a Web browser

- SNMP Community Name
- Monitor Password

Displaying the Web Control screen

Use the following procedure to display the Web Control screen.



If your Web browser is set up to connect via a proxy server, the Web Control screen cannot be displayed. To display Web Control, you need to make settings so that a proxy server is not used for a connection.

- 1** Start the Web browser on the computer.
- 2** Enter the IP address of the projector in the address input box of the Web browser, and press the Enter key on the computer's keyboard.
The Web Control screen is displayed.
When Web Control Password is set in the Network menu from the projector's Configuration menu, the password entry screen is displayed.

Displaying the Web Remote screen

The Web Remote function allows you to perform projector remote control operations with a Web browser.

- 1** Display the Web Control screen.

2 Click Web Remote.



3 The Web Remote screen is displayed.

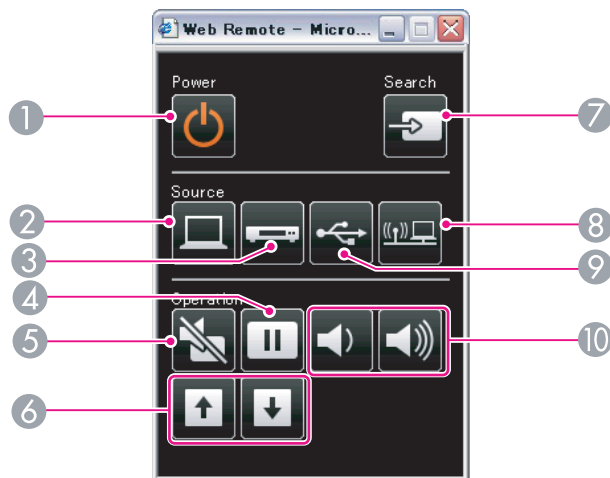

Name	Function
1 [Power] button	Turns the projector power on or off. ☛ "From Installation to Projection" p.26
2 [Computer] button	Changes to images from the Computer port.
3 [Video] button	Each time you press the button, the input source changes between images from the Video port and the HDMI port (EB-1775W/EB-1770W/EB-1760W only).
4 [Freeze] button	Images are paused or unpaused. ☛ "Freezing the Image (Freeze)" p.52

Name	Function
5 [A/V Mute] button	Turns the video and audio on or off. ☛ "Hiding the Image and Sound Temporarily (A/V Mute)" p.51
6 [Page] buttons [Up] [Down]	Changes pages in files such as PowerPoint files when using the following projection methods. <ul style="list-style-type: none"> • When using the Wireless Mouse function ☛ "Using the Remote Control to Operate the Mouse Pointer (Wireless Mouse)" p.54 • When using USB Display ☛ "Projecting with USB Display" p.28 • During a network connection (EB-1775W/EB-1770W/EB-1760W only) When projecting images or scenarios using Slideshow, pressing these buttons displays the previous/next screen.
7 [Source Search] button	Changes to the next input source that is sending an image. ☛ "Automatically Detect Input Signals and Change the Projected Image (Source Search)" p.27
8 [LAN] button	Changes to the image projected with EasyMP Network Projection. When projecting using the supplied or optional Quick Wireless Connection USB Key, this button switches to that image. (EB-1775W/EB-1770W/EB-1760W only) ☛ "Switching to the Target Image by Remote Control" p.28
9 [USB] button	Each time the button is pressed, it cycles through the following images: <ul style="list-style-type: none"> • USB Display • Images from the device connected to the USB port ☛ "Switching to the Target Image by Remote Control" p.28
10 [Volume] buttons [Mute] [Volume Up] [Volume Down]	[Mute] Decreases the volume. [Volume Up] Increases the volume. ☛ "Adjusting the Volume" p.38

Using the Mail Notification Function to Report Problems

When you set Mail Notification, notification messages are sent to the preset email addresses when a problem or warning occurs with a projector. This will enable the operator to be notified of problems with projectors even at locations away from the projectors.

 [Network - Mail - Mail Notification p.82](#)



- Up to a maximum of three notification destinations (addresses) can be registered, and notification messages can be sent to all three destinations at once.
- If a projector develops a critical problem and suddenly stops working, it may not be able to send a message notifying an operator of the problem.
- If you set **Standby Mode** to **Communication On**, you can control the projector even if it is in standby mode (when the power is off).

 [Extended - Standby Mode p.74](#)

Reading Error Notification Mail

When the Mail Notification function is set to On and a problem or warning occurs in the projector, the following email will be sent.

Subject: EPSON Projector

Line 1: The projector name where the problem has occurred

Line 2: The IP address set for the projector where the problem has occurred.

Line 3 and on: Details of the problem

The following messages are listed line by line to indicate the details of the problem. See the following to deal with problems or warnings.

 ["Reading the Indicators" p.88](#)

- Internal error
- Fan related error
- Sensor error
- Lamp timer failure
- Lamp out
- Internal temperature error
- High-speed cooling in progress
- Lamp replacement notification
- No-signal
- Auto Iris Error
- Power Err. (Ballast)

A (+) or (-) appears at the start of the message.

(+): A projector problem has occurred

(-): A projector problem has been dealt with

Management Using SNMP

By setting **SNMP** to **On**, notification messages are sent to preset email addresses when a problem or warning occurs. This will enable the operator to be notified of problems with projectors even at locations away from the projectors.

 [Network - Others - SNMP p.82](#)



- SNMP should be managed by a network administrator or someone who is familiar with the network.
- To use the SNMP function to monitor the projector, you need to install the SNMP manager program on your computer.
- The managing function using SNMP cannot be used via wireless LAN in Quick connection mode.
- Up to two destination IP addresses can be saved.

ESC/VP21 Commands

You can monitor and control the projector from a computer via USB. Connect the device and the projector with a USB cable, and then enter the communication commands (ESC/VP21 commands).

Before starting

To control and monitor the projector using ESC/VP21 commands, the following preparations must be carried out.

- 1** Install the USB communication driver (EPSON USB-COM Driver) to your computer. For information about the EPSON USB-COM Driver, contact your local dealer or the nearest address provided in the Epson Projector Contact List.
 - ☛ [Epson Projector Contact List](#)
- 2** Set **USB Type B** to **Link 21L** from the projector's Configuration menu.
 - ☛ **Extended** - [USB Type B p.74](#)
- 3** Set **Link 21L** to **On**.
 - ☛ **Extended** - [Link 21L p.74](#)
- 4** Connect the computer's USB port to the projector's USB (Type B) port with a USB cable.

Start from step 2 from the second time.

Command list

When the power ON command is transmitted to the projector, the power turns on and it enters warm-up mode. When the projector's power has turned on, a colon ":" (3Ah) is returned.

When a command is input, the projector executes the command and returns a ":", and then accepts the next command.

If the command being processed terminates abnormally, an error message is output and a ":" is returned.

Item		Command	
Power ON/OFF	On	PWR ON	
	Off	PWR OFF	
Signal selection	Computer	Auto	SOURCE 1F
		RGB	SOURCE 11
		Component	SOURCE 14
	HDMI (EB-1775W/EB-1770W/ EB-1760W only)		SOURCE 30
	Video		SOURCE 41
	USB Display		SOURCE 51
	USB		SOURCE 52
A/V Mute On/Off	On	MUTE ON	
	Off	MUTE OFF	
A/V Mute selection	Black	MSEL 00	
	Blue	MSEL 01	
	Logo	MSEL 02	
LAN (EB-1775W/EB-1770W/EB-1760W only)		SOURCE 53	

Add a Carriage Return (CR) code (0Dh) to the end of each command and transmit.

Communications protocol



- Default baud rate setting: 9600 bps
- Data length: 8 bit
- Parity: None



- Stop-bit: 1 bit
- Flow control: None

Check the numbers and then apply the following countermeasures. If you cannot resolve the problem, contact your network administrator, or contact your local dealer or the nearest address provided in the Epson Projector Contact List.

 [Epson Projector Contact List](#)

Event ID	Cause	Remedy
0432 0435	Failed to startup EasyMP Network Projection.	Restart the projector.
0434 0482 0484 0485	Network communication is unstable.	Check the network communication status, and reconnect after waiting for a while.
0433	Cannot play transferred images.	Restart EasyMP Network Projection.
0481	Communication was disconnected from the computer.	
0483 04FE	EasyMP Network Projection ended unexpectedly.	Check the network communication status, and then restart the projector.
0479 04FF	A system error occurred in the projector.	Restart the projector.
0891	Cannot find an access point with the same SSID.	Set the computer, the access point, and the projector to the same SSID.
0892	The WPA/WPA2 authentication type does not match.	Check that the wireless LAN security settings are correct.
0893	The WEP/TKIP/AES encryption type does not match.	 Security p.80
0894	Communication was disconnected because the projector connected to an unauthorized access point.	Contact your network administrator for more information.
0898	Failed to acquire DHCP.	Check that the DHCP server is operating correctly. If you are not using DHCP, turn off the DHCP setting.  Wireless LAN - IP Settings p.79
0895 0899	Other communication errors	If restarting the projector or EasyMP Network Projection does not solve the problem, contact your local dealer or the nearest address provided in the Epson Projector Contact List.  Epson Projector Contact List

PJLink Class1 was established by the JBMIA (Japan Business Machine and Information System Industries Association) as a standard protocol for controlling network-compatible projector's as part of their efforts to standardize projector control protocols.

The projector complies with the PJLink Class1 standard established by the JBMIA.

It complies with all commands except for the following commands defined by PJLink Class1, and agreement was confirmed by the PJLink standard adaptability verification.

URL: <http://pjlink.jbmia.or.jp/english/>

- **Non-compatible commands**

	Function	PJLink Command
Mute settings	Image muting set	AVMT 11
	Audio muting set	AVMT 21

- **Input names defined by PJLink and corresponding projector sources**

Source	PJLink Command
Computer	INPT 11
Video	INPT 21
HDMI	INPT 32
USB	INPT 41
LAN	INPT 52
USB Display	INPT 53

- Manufacturer name displayed for "Manufacture name information query"
EPSON

- Model name displayed for "Product name information query"
EB-1775W/PowerLite 1775W/EB-C300MS
EB-1770W/PowerLite 1770W/EB-C300MN/EB-C3010WN
EB-1760W/PowerLite 1760W/EB-C260MN

Projection Distance (For EB-1775W/EB-1770W/EB-1760W)

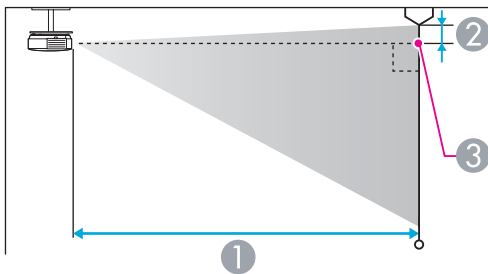
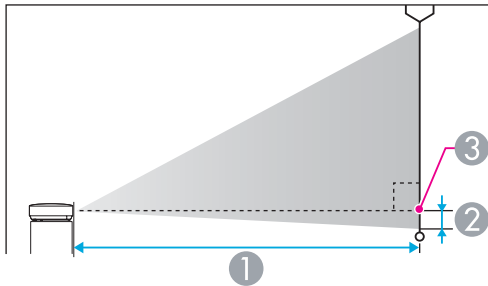

- ① Projection distance
- ② Distance from the center of the lens to the base of the screen (or to the top of the screen, if suspended from a ceiling)
- ③ Center of lens

Unit: cm

4:3 Screen Size		①	②
		Minimum (Wide) to Maximum (Tele)	
28"	57x43	71 - 85	-4
30"	61x46	76 - 91	-4

4:3 Screen Size		①	②
		Minimum (Wide) to Maximum (Tele)	
40"	81x61	102 - 122	-6
50"	100x76	127 - 153	-7
60"	120x91	153 - 184	-8
80"	160x120	205 - 246	-11
100"	200x150	256 - 308	-14
150"	300x230	385 - 462	-21
200"	410x300	514 - 617	-28
250"	500x380	643 - 771	-35
260"	520x400	668 - 802	-36

Unit: cm

16:9 Screen Size		①	②
		Minimum (Wide) to Maximum (Tele)	
30"	66x37	69 - 83	-2
40"	89x50	92 - 111	-2
50"	110x62	115 - 139	-3
60"	130x75	139 - 167	-3
70"	160x87	162 - 195	-4
80"	180x100	186 - 223	-5
100"	220x120	232 - 279	-6
150"	330x190	349 - 419	-8
200"	440x250	466 - 560	-11
250"	550x310	583 - 700	-14
280"	620x350	653 - 784	-16

Unit: cm

16:10 Screen Size		①	
		Minimum (Wide) to Maximum (Tele)	
30"	64x40	67 - 80	
40"	86x54	89 - 108	
50"	110x67	112 - 135	
60"	130x81	135 - 162	
80"	170x110	181 - 217	
100"	220x130	226 - 271	
150"	320x200	340 - 408	
200"	430x270	454 - 545	
250"	540x340	567 - 681	
300"	640x400	681 - 818	

②

Projection Distance (For EB-1750)

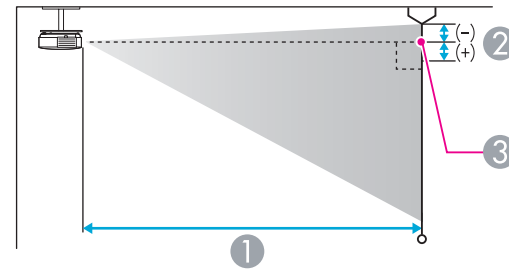
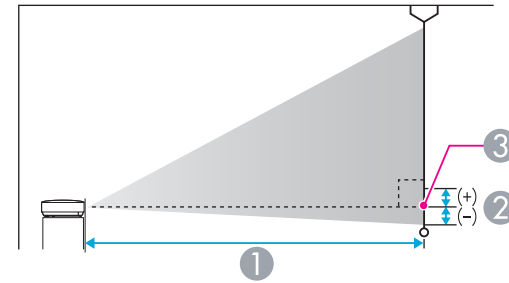

- ① Projection distance
- ② Distance from the center of the lens to the base of the screen (or to the top of the screen, if suspended from a ceiling)
- ③ Center of lens

Unit: cm

4:3 Screen Size		①	
		Minimum (Wide) to Maximum (Tele)	
30"	61x46	72 - 86	
40"	81x61	96 - 116	
50"	100x76	120 - 145	

②

4:3 Screen Size		①	②
		Minimum (Wide) to Maximum (Tele)	
60"	120x91	145 - 174	-10
80"	160x120	194 - 233	-14
100"	200x150	242 - 291	-17
150"	300x230	364 - 438	-26
200"	410x300	486 - 584	-34
250"	510x380	608 - 730	-43
300"	610x460	730 - 877	-51

Unit: cm

16:9 Screen Size		①	②
		Minimum (Wide) to Maximum (Tele)	
30"	66x37	78 - 94	+1
40"	89x50	105 - 126	+1
50"	110x62	131 - 158	+1
60"	130x75	158 - 190	+1
70"	160x87	185 - 222	+1
80"	180x100	211 - 254	+2
100"	220x120	264 - 317	+2
150"	330x190	397 - 477	+3
200"	440x250	530 - 636	+4
250"	550x310	663 - 796	+5
275"	610x340	729 - 875	+6

Supported Resolutions

Computer signals (analog RGB)

Signal	Refresh Rate (Hz)	Resolution (dots)
VGA	60/72/75/85	640x480
SVGA	56/60/72/75/85	800x600
XGA	60/70/75/85	1024x768
WXGA	60	1280x768
	60	1360x768
	60/75/85	1280x800
WXGA+	60/75/85	1440x900
SXGA	70/75/85	1152x864
	60/75/85	1280x1024
	60/75/85	1280x960
SXGA+	60/75	1400x1050
WSXGA+*1, 2	60	1680x1050
UXGA	60	1600x1200
MAC13"	67	640x480
MAC16"	75	832x624
MAC19"	75	1024x768
	59	1024x768
MAC21"	75	1152x870

*1 (EB-1775W/EB-1770W/EB-1760W only)

*2 Only compatible when **Wide** is selected as the **Resolution** from the Configuration menu.

Even when signals other than those mentioned above are input, it is likely that the image can be projected. However, not all functions may be supported.

Component video

Signal	Refresh Rate (Hz)	Resolution (dots)
SDTV (480i)	60	720x480
SDTV (576i)	50	720x576
SDTV (480p)	60	720x480
SDTV (576p)	50	720x576
HDTV (720p)	50/60	1280x720
HDTV (1080i)	50/60	1920x1080
HDTV (1080p)	24/30/50/60	1920x1080

Composite video

Signal	Refresh Rate (Hz)	Resolution (dots)
TV (NTSC)	60	720x480
TV (SECAM)	50	720x576
TV (PAL)	50/60	720x576

Input signal from the HDMI port (EB-1775W/EB-1770W/EB-1760W only)

Signal	Refresh Rate (Hz)	Resolution (dots)
VGA	60	640x480
SVGA	60	800x600
XGA	60	1024x768
WXGA	60	1280x800
SXGA	60	1280x960
	60	1280x1024
SXGA+	60	1400x1050



Signal	Refresh Rate (Hz)	Resolution (dots)
UXGA	60	1600x1200
SDTV (480i/480p)	60	720x480
SDTV (576i/576p)	50	720x576
HDTV (720p)	50/60	1280x720
HDTV (1080i)	50/60	1920x1080
HDTV (1080p)	24/30/50/60	1920x1080

Projector General Specifications

Product name		EB-1775W	EB-1770W	EB-1760W	EB-1750
Dimensions		292 (W) x 44 (H) x 210 (D) mm (not including raised section)			
LCD panel size		0.59" Wide			0.55"
Display method		Polysilicon TFT active matrix			
Resolution		1,024,000 pixels WXGA (1280 (W)x 800 (H) dots)x 3			786,432 pixels XGA (1024 (W) x 768 (H) dots)x 3
Focus adjustment		Electric/Auto	Manual		
Zoom adjustment		Manual (1 to 1.2)			
Lamp		UHE lamp, 230 W Model No.: ELPLP65	UHE lamp, 205 W Model No.: ELPLP65	UHE lamp, 230 W Model No.: ELPLP65	
Max. audio output		1 W monaural			
Speaker		1			
Power supply		100 to 240 V AC \pm 10%, 50/60 Hz 3.3 to 1.5 A	100 to 240 V AC \pm 10%, 50/60 Hz 3.0 to 1.4 A	100 to 240 V AC \pm 10%, 50/60 Hz 3.3 to 1.5 A	
Power consumption	100 to 120 V area	Operating: 322 W Standby power consumption (Communication On): 7.4 W Standby power consumption (Communication Off): 0.38 W	Operating: 293 W Standby power consumption (Communication On): 7.4 W Standby power consumption (Communication Off): 0.38 W	Operating: 322 W Standby power consumption (Communication On): 7.4 W Standby power consumption (Communication Off): 0.38 W	
	220 to 240 V area	Operating: 304 W Standby power consumption (Communication On): 7.7 W Standby power consumption (Communication Off): 0.44 W	Operating: 278 W Standby power consumption (Communication On): 7.7 W Standby power consumption (Communication Off): 0.44 W	Operating: 304 W Standby power consumption (Communication On): 7.7 W Standby power consumption (Communication Off): 0.44 W	
Operating altitude		Altitude 0 to 2,286 m			
Operating temperature		5 to +35°C (No condensation)			
Storage temperature		-10 to +60°C (No condensation)			

Mass	Approx. 1.7 kg
-------------	----------------

Product name			EB-1775W	EB-1770W	EB-1760W	EB-1750
Con- nec- tors	Computer port	1	Mini D-Sub15-pin (female)			
	Video port	1	RCA pin jack			
	Audio port	1	Stereo mini jack			
	HDMI port	1	HDMI (Audio is only supported by PCM)			-
	USB (TypeA) Port*	1	USB connector (Type A)			
	USB (TypeB) Port*	1	USB connector (Type B)			
	USB port (dedicated Wireless LAN unit)	1	USB connector (Type A)			-

* Supports USB 2.0. However, USB ports are not guaranteed to operate all devices that support USB.

This product is also designed for IT power distribution system with phase-to-phase voltage 230V.

Angle of tilt

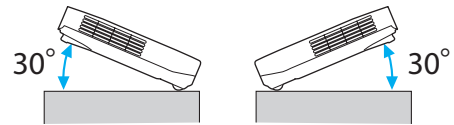

If you use the projector tilted at an angle of more than 30° it could be damaged and cause an accident.

DECLARATION of CONFORMITY

According to 47CFR, Part 2 and 15

Class B Personal Computers and Peripherals; and/or
CPU Boards and Power Supplies used with Class B Personal Computers

We: Epson America, Inc.
Located at: 3840 Kilroy Airport Way
MS: 3-13
Long Beach, CA 90806
Tel: 562-290-5254

Declare under sole responsibility that the product identified herein, complies with 47CFR Part 2 and 15 of the FCC rules as a Class B digital device. Each product marketed, is identical to the representative unit tested and found to be compliant with the standards. Records maintained continue to reflect the equipment being produced can be expected to be within the variation accepted, due to quantity production and testing on a statistical basis as required by 47CFR 2.909. Operation is subject to the following two conditions : (1) this device may not cause harmful interference, and (2) this device must accept any interference received, including interference that may cause undesired operation.

Trade Name: EPSON
Type of Product: Projector
Model: H361C/H362C/H363C/H372C

FCC Compliance Statement For United States Users

This equipment has been tested and found to comply with the limits for a Class B digital device, pursuant to Part 15 of the FCC Rules. These limits are designed to provide reasonable protection against harmful interference in a residential installation. This equipment generates, uses, and can radiate radio frequency energy and, if not installed and used in accordance with the instructions, may cause harmful interference to radio or television reception. However, there is no guarantee that interference will not occur in a particular installation. If this equipment does cause interference to radio and television reception, which can be determined by turning the equipment off and on, the user is encouraged to try to correct the interference by one or more of the following measures.

- Reorient or relocate the receiving antenna.
- Increase the separation between the equipment and receiver.
- Connect the equipment into an outlet on a circuit different from that to which the receiver is connected.
- Consult the dealer or an experienced radio/TV technician for help.

WARNING

The connection of a non-shielded equipment interface cable to this equipment will invalidate the FCC Certification or Declaration of this device and may cause interference levels which exceed the limits established by the FCC for this equipment. It is the responsibility of the user to obtain and use a shielded equipment interface cable with this device. If this equipment has more than one interface connector, do not leave cables connected to unused interfaces. Changes or modifications not expressly approved by the manufacturer could void the user's authority to operate the equipment.

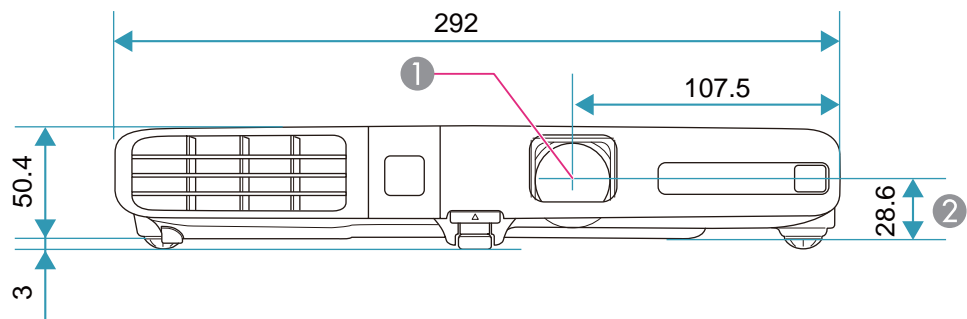

- ① Center of lens
- ② Distance from center of lens to suspension bracket fixing point

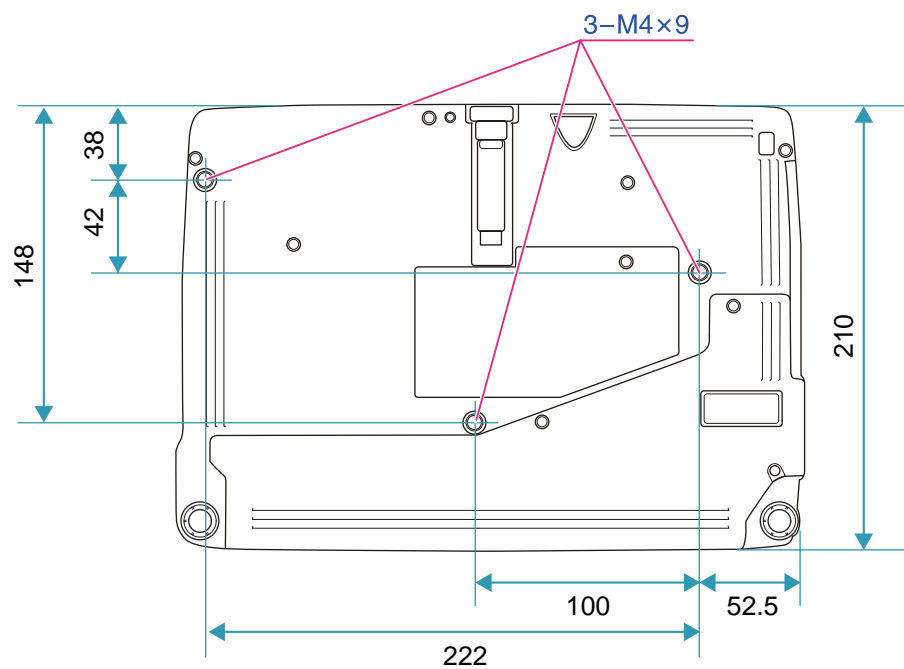

Units: mm

This section briefly explains the difficult terms that are not explained in the text of this guide. For details, refer to other commercially available publications.

AMX Device Discovery	AMX Device Discovery is a technology developed by AMX to facilitate AMX control systems for easy operation of the target equipment. Epson have implemented this protocol technology, and have provided a setting to enable the protocol function (ON). See the AMX Web site for more details. URL http://www.amx.com/
Aspect Ratio	The ratio between an image's length and its height. Screens with a horizontal:vertical ratio of 16:9, such as HDTV screens, are known as wide screens. SDTV and general computer displays have an aspect ratio of 4:3.
Component Video	A method that separates the video signal into a luminance component (Y), and a blue minus luminance (Cb or Pb) and a red minus luminance (Cr or Pr).
Composite video	A method that combines the video signal into a luminance component and a color component for transmission down a single cable.
Contrast	The relative brightness of the light and dark areas of an image can be increased or decreased to make text and graphics stand out more clearly, or to make them appear softer. Adjusting this particular property of an image is called contrast adjustment.
DHCP	An abbreviation of Dynamic Host Configuration Protocol, this protocol automatically assigns an IP address to equipment connected to a network.
Gateway Address	This is a server (router) for communicating across a network (subnet) divided according to subnet mask .
HDCP	HDCP is an abbreviation for High-bandwidth Digital Content Protection. It is used to prevent illegal copying and protect copyrights by encrypting digital signals sent over DVI and HDMI ports. Because the HDMI port on this projector supports HDCP, it can project digital images protected by HDCP technology. However, the projector may not be able to project images protected with updated or revised versions of HDCP encryption.
HDTV	An abbreviation for High-Definition Television that refers to high-definition systems which satisfy the following conditions. <ul style="list-style-type: none"> • Vertical resolution of 720p or 1080i or greater (p = Progressive, i = Interlace) • Screen aspect ratio of 16:9
Interlace	Transmits information needed to create one screen by sending every other line, starting from the top of the image and working down to the bottom. Images are more likely to flicker because one frame is displayed every other line.
IP Address	A number to identify a computer connected to a network.
Progressive	Projects information to create one screen at a time, displaying the image for one frame. Even though the number of scan lines is the same, the amount of flicker in images decreases because the volume of information has doubled compared with an interlace system.
SDTV	An abbreviation for Standard Definition Television that refers to standard television systems which do not satisfy the conditions for HDTV High-Definition Television.
SNMP	An abbreviation for Simple Network Management Protocol, which is the protocol for monitoring and controlling devices such as routers and computers connected to a TCP/IP network.

sRGB	An international standard for color intervals that was formulated so that colors that are reproduced by video equipment can be handled easily by computer operating systems (OS) and the Internet. If the connected source has an sRGB mode, set both the projector and the connected signal source to sRGB.
SSID	SSID is identification data for connecting to another device on a wireless LAN. Wireless communication is possible between devices with matching SSID.
Subnet Mask	This is a numerical value that defines the number of bits used for the network address on a divided network (subnet) from the IP address.
SVGA	A screen size standard with a resolution of 800 (horizontal) x 600 (vertical) dots.
S-Video	A method that separates the video signal into a luminance component (Y) and a color component (C).
SXGA	A screen size standard with a resolution of 1,280 (horizontal) x 1,024 (vertical) dots.
Sync.	The signals output from computers have a specific frequency. If the projector frequency does not match this frequency, the resulting images are not of a good quality. The process of matching the phases of these signals (the relative position of the crests and the troughs in the signal) is called Synchronization. If the signals are not synchronized, flickering, blurriness, and horizontal interference occur.
Tracking	The signals output from computers have a specific frequency. If the projector frequency does not match this frequency, the resulting images are not of a good quality. The process of matching the frequency of these signals (the number of crests in the signal) is called Tracking. If Tracking is not carried out correctly, wide vertical stripes appear in the signal.
Trap IP Address	This is the IP address for the destination computer used for error notification in SNMP.
VGA	A screen size standard with a resolution of 640 (horizontal) x 480 (vertical) dots.
XGA	A screen size standard with a resolution of 1,024 (horizontal) x 768 (vertical) dots.

All rights reserved. No part of this publication may be reproduced, stored in a retrieval system, or transmitted in any form or by any means, electronic, mechanical, photocopying, recording, or otherwise, without the prior written permission of Seiko Epson Corporation. No patent liability is assumed with respect to the use of the information contained herein. Neither is any liability assumed for damages resulting from the use of the information contained herein.

Neither Seiko Epson Corporation nor its affiliates shall be liable to the purchaser of this product or third parties for damages, losses, costs, or expenses incurred by the purchaser or third parties as a result of: accident, misuse, or abuse of this product or unauthorized modifications, repairs, or alterations to this product, or (excluding the U.S.) failure to strictly comply with Seiko Epson Corporation's operating and maintenance instructions.

Seiko Epson Corporation shall not be liable against any damages or problems arising from the use of any options or any consumable products other than those designated as Original Epson Products or Epson Approved Products by Seiko Epson Corporation.

The contents of this guide may be changed or updated without further notice.

Illustrations in this guide and the actual projector may differ.

About Notations

Microsoft® Windows® 98 operating system
Microsoft® Windows® Me operating system
Microsoft® Windows® 2000 operating system
Microsoft® Windows® XP Professional operating system
Microsoft® Windows® XP Home Edition operating system
Microsoft® Windows Vista® operating system
Microsoft® Windows® 7 operating system

In this guide, the operating systems above are referred to as "Windows 98", "Windows Me", "Windows 2000", "Windows XP", "Windows Vista", and "Windows 7". Furthermore, the collective term Windows may be used to refer to Windows 98, Windows Me, Windows 2000, Windows XP,

Windows Vista, and Windows 7, and multiple versions of Windows may be referred to as, for example, Windows 98/Me/2000/XP/Vista, with the Windows notation omitted.

Mac OS X 10.3.x
Mac OS X 10.4.x
Mac OS X 10.5.x
Mac OS X 10.6.x

In this guide, the operating systems above are referred to as "Mac OS X 10.3.9", "Mac OS X 10.4.x", "Mac OS X 10.5.x", and "Mac OS X 10.6.x". Furthermore, the collective term "Mac OS" is used to refer to them.

General Notice:

IBM, DOS/V, and XGA are trademarks or registered trademarks of International Business Machines Corporation.

Macintosh, Mac, Mac OS, and iMac are trademarks of Apple Inc.

Microsoft, Windows, Windows NT, Windows Vista, Windows 7, PowerPoint, and Windows logo are trademarks or registered trademarks of Microsoft Corporation in the United States and/or other countries.

WPA™ and WPA2™ are registered trademarks of Wi-Fi Alliance.

HDMI and High-Definition Multimedia Interface are the trademarks or registered trademarks of HDMI Licensing LLC. 

PJLink trademark is a trademark applied for registration or is already registered in Japan, the United States of America and other countries and areas.

Other product names used herein are also for identification purposes only and may be trademarks of their respective owners. Epson disclaims any and all rights in those marks.

©SEIKO EPSON CORPORATION 2010. All rights reserved.

GNU GPL

This projector product includes the open source software programs which apply the GNU General Public License Version 2 or later version ("GPL Programs").

We provide the source code of the GPL Programs until five (5) years after the discontinuation of same model of this projector product.

If you desire to receive the source code of the GPL Programs, please see the "EPSON Projector Contact List" in the User's Guide, and contact the customer support of your region.

These GPL Programs are WITHOUT ANY WARRANTY; without even the implied warranty of MERCHANTABILITY AND FITNESS FOR A PARTICULAR PURPOSE. See the GNU General Public License for more details.

The list of GPL Programs is as follows and the names of author are described in the source code of the GPL Programs

The list of GPL Programs

busybox-1.13.4

iptables-1.4.2

libgcc1(gcc-4.3.3)

linux-2.6.27

patches

udhcp 0.9.8

uvc rev.219

wireless_tools 29

EPSON original drivers

The GNU General Public License Version 2 is as follows. You also can see the GNU General Public License Version 2 at <http://www.gnu.org/licenses/>.

GNU GENERAL PUBLIC LICENSE

Version 2, June 1991

Copyright (C) 1989, 1991 Free Software Foundation, Inc., 51 Franklin Street, Fifth Floor, Boston, MA 02110-1301 USA Everyone is permitted to copy and distribute verbatim copies of this license document, but changing it is not allowed.

Preamble

The licenses for most software are designed to take away your freedom to share and change it. By contrast, the GNU General Public License is intended to guarantee your freedom to share and change free software--to make sure the software is free for all its users. This General Public License applies to most of the Free Software Foundation's software and to any other program whose authors commit to using it. (Some other Free Software Foundation software is covered by the GNU Lesser General Public License instead.) You can apply it to your programs, too.

When we speak of free software, we are referring to freedom, not price. Our General Public Licenses are designed to make sure that you have the freedom to distribute copies of free software (and charge for this service if you wish), that you receive source code or can get it if you want it, that you can change the software or use pieces of it in new free programs; and that you know you can do these things.

To protect your rights, we need to make restrictions that forbid anyone to deny you these rights or to ask you to surrender the rights. These restrictions translate to certain responsibilities for you if you distribute copies of the software, or if you modify it.

For example, if you distribute copies of such a program, whether gratis or for a fee, you must give the recipients all the rights that you have. You must make sure that they, too, receive or can get the source code. And you must show them these terms so they know their rights.

We protect your rights with two steps: (1) copyright the software, and (2) offer you this license which gives you legal permission to copy, distribute and/or modify the software.

Also, for each author's protection and ours, we want to make certain that everyone understands that there is no warranty for this free software. If the software is modified by someone else and passed on, we want its recipients to know that what they have is not the original, so that any problems introduced by others will not reflect on the original authors' reputations.

Finally, any free program is threatened constantly by software patents. We wish to avoid the danger that redistributors of a free program will individually obtain patent licenses, in effect making the program proprietary. To prevent this, we have made it clear that any patent must be licensed for everyone's free use or not licensed at all.

The precise terms and conditions for copying, distribution and modification follow.

GNU GENERAL PUBLIC LICENSE TERMS AND CONDITIONS FOR COPYING, DISTRIBUTION AND MODIFICATION

0. This License applies to any program or other work which contains a notice placed by the copyright holder saying it may be distributed under the terms of this General Public License. The "Program", below, refers to any such program or work, and a "work based on the Program" means either the Program or any derivative work under copyright law: that is to say, a work containing the Program or a portion of it, either verbatim or with modifications and/or translated into another language. (Hereinafter, translation is included without limitation in the term "modification".) Each licensee is addressed as "you".

Activities other than copying, distribution and modification are not covered by this License; they are outside its scope. The act of running the Program is not restricted, and the output from the Program is covered only if its contents constitute a work based on the Program (independent of having been made by running the Program). Whether that is true depends on what the Program does.

1. You may copy and distribute verbatim copies of the Program's source code as you receive it, in any medium, provided that you conspicuously and appropriately publish on each copy an appropriate copyright notice and disclaimer of warranty; keep intact all the notices that refer to this License and to the absence of any warranty; and give any other recipients of the Program a copy of this License along with the Program.

You may charge a fee for the physical act of transferring a copy, and you may at your option offer warranty protection in exchange for a fee.

2. You may modify your copy or copies of the Program or any portion of it, thus forming a work based on the Program, and copy and distribute such modifications or work under the terms of Section 1 above, provided that you also meet all of these conditions:
- a) You must cause the modified files to carry prominent notices stating that you changed the files and the date of any change.
 - b) You must cause any work that you distribute or publish, that in whole or in part contains or is derived from the Program or any part thereof, to be licensed as a whole at no charge to all third parties under the terms of this License.

- c) If the modified program normally reads commands interactively when run, you must cause it, when started running for such interactive use in the most ordinary way, to print or display an announcement including an appropriate copyright notice and a notice that there is no warranty (or else, saying that you provide a warranty) and that users may redistribute the program under these conditions, and telling the user how to view a copy of this License. (Exception: if the Program itself is interactive but does not normally print such an announcement, your work based on the Program is not required to print an announcement.)

These requirements apply to the modified work as a whole. If identifiable sections of that work are not derived from the Program, and can be reasonably considered independent and separate works in themselves, then this License, and its terms, do not apply to those sections when you distribute them as separate works. But when you distribute the same sections as part of a whole which is a work based on the Program, the distribution of the whole must be on the terms of this License, whose permissions for other licensees extend to the entire whole, and thus to each and every part regardless of who wrote it.

Thus, it is not the intent of this section to claim rights or contest your rights to work written entirely by you; rather, the intent is to exercise the right to control the distribution of derivative or collective works based on the Program.

In addition, mere aggregation of another work not based on the Program with the Program (or with a work based on the Program) on a volume of a storage or distribution medium does not bring the other work under the scope of this License.

3. You may copy and distribute the Program (or a work based on it, under Section 2) in object code or executable form under the terms of Sections 1 and 2 above provided that you also do one of the following:
- a) Accompany it with the complete corresponding machine-readable source code, which must be distributed under the terms of Sections 1 and 2 above on a medium customarily used for software interchange; or,
 - b) Accompany it with a written offer, valid for at least three years, to give any third party, for a charge no more than your cost of physically performing source distribution, a complete machine-readable copy of the corresponding source code, to be distributed under the terms of Sections 1 and 2 above on a medium customarily used for software interchange; or,

- c) Accompany it with the information you received as to the offer to distribute corresponding source code. (This alternative is allowed only for noncommercial distribution and only if you received the program in object code or executable form with such an offer, in accord with Subsection b above.)

The source code for a work means the preferred form of the work for making modifications to it. For an executable work, complete source code means all the source code for all modules it contains, plus any associated interface definition files, plus the scripts used to control compilation and installation of the executable. However, as a special exception, the source code distributed need not include anything that is normally distributed (in either source or binary form) with the major components (compiler, kernel, and so on) of the operating system on which the executable runs, unless that component itself accompanies the executable.

If distribution of executable or object code is made by offering access to copy from a designated place, then offering equivalent access to copy the source code from the same place counts as distribution of the source code, even though third parties are not compelled to copy the source along with the object code.

4. You may not copy, modify, sublicense, or distribute the Program except as expressly provided under this License. Any attempt otherwise to copy, modify, sublicense or distribute the Program is void, and will automatically terminate your rights under this License. However, parties who have received copies, or rights, from you under this License will not have their licenses terminated so long as such parties remain in full compliance.
5. You are not required to accept this License, since you have not signed it. However, nothing else grants you permission to modify or distribute the Program or its derivative works. These actions are prohibited by law if you do not accept this License. Therefore, by modifying or distributing the Program (or any work based on the Program), you indicate your acceptance of this License to do so, and all its terms and conditions for copying, distributing or modifying the Program or works based on it.
6. Each time you redistribute the Program (or any work based on the Program), the recipient automatically receives a license from the original licensor to copy, distribute or modify the Program subject to these terms and conditions. You may not impose any further restrictions on the recipients' exercise of the rights granted herein. You are not responsible for enforcing compliance by third parties to this License.

7. If, as a consequence of a court judgment or allegation of patent infringement or for any other reason (not limited to patent issues), conditions are imposed on you (whether by court order, agreement or otherwise) that contradict the conditions of this License, they do not excuse you from the conditions of this License. If you cannot distribute so as to satisfy simultaneously your obligations under this License and any other pertinent obligations, then as a consequence you may not distribute the Program at all. For example, if a patent license would not permit royalty-free redistribution of the Program by all those who receive copies directly or indirectly through you, then the only way you could satisfy both it and this License would be to refrain entirely from distribution of the Program.

If any portion of this section is held invalid or unenforceable under any particular circumstance, the balance of the section is intended to apply and the section as a whole is intended to apply in other circumstances.

It is not the purpose of this section to induce you to infringe any patents or other property right claims or to contest validity of any such claims; this section has the sole purpose of protecting the integrity of the free software distribution system, which is implemented by public license practices. Many people have made generous contributions to the wide range of software distributed through that system in reliance on consistent application of that system; it is up to the author/donor to decide if he or she is willing to distribute software through any other system and a licensee cannot impose that choice.

This section is intended to make thoroughly clear what is believed to be a consequence of the rest of this License.

8. If the distribution and/or use of the Program is restricted in certain countries either by patents or by copyrighted interfaces, the original copyright holder who places the Program under this License may add an explicit geographical distribution limitation excluding those countries, so that distribution is permitted only in or among countries not thus excluded. In such case, this License incorporates the limitation as if written in the body of this License.
9. The Free Software Foundation may publish revised and/or new versions of the General Public License from time to time. Such new versions will be similar in spirit to the present version, but may differ in detail to address new problems or concerns.

Each version is given a distinguishing version number. If the Program specifies a version number of this License which applies to it and "any later version", you have the option of following the terms and conditions either of that version or of any later version published by the Free Software Foundation. If the Program does not specify a version number of this License, you may choose any version ever published by the Free Software Foundation.

10. If you wish to incorporate parts of the Program into other free programs whose distribution conditions are different, write to the author to ask for permission. For software which is copyrighted by the Free Software Foundation, write to the Free Software Foundation; we sometimes make exceptions for this. Our decision will be guided by the two goals of preserving the free status of all derivatives of our free software and of promoting the sharing and reuse of software generally.

NO WARRANTY

11. BECAUSE THE PROGRAM IS LICENSED FREE OF CHARGE, THERE IS NO WARRANTY FOR THE PROGRAM, TO THE EXTENT PERMITTED BY APPLICABLE LAW. EXCEPT WHEN OTHERWISE STATED IN WRITING THE COPYRIGHT HOLDERS AND/OR OTHER PARTIES PROVIDE THE PROGRAM "AS IS" WITHOUT WARRANTY OF ANY KIND, EITHER EXPRESSED OR IMPLIED, INCLUDING, BUT NOT LIMITED TO, THE IMPLIED WARRANTIES OF MERCHANTABILITY AND FITNESS FOR A PARTICULAR PURPOSE. THE ENTIRE RISK AS TO THE QUALITY AND PERFORMANCE OF THE PROGRAM IS WITH YOU. SHOULD THE PROGRAM PROVE DEFECTIVE, YOU ASSUME THE COST OF ALL NECESSARY SERVICING, REPAIR OR CORRECTION.
12. IN NO EVENT UNLESS REQUIRED BY APPLICABLE LAW OR AGREED TO IN WRITING WILL ANY COPYRIGHT HOLDER, OR ANY OTHER PARTY WHO MAY MODIFY AND/OR REDISTRIBUTE THE PROGRAM AS PERMITTED ABOVE, BE LIABLE TO YOU FOR DAMAGES, INCLUDING ANY GENERAL, SPECIAL, INCIDENTAL OR CONSEQUENTIAL DAMAGES ARISING OUT OF THE USE OR INABILITY TO USE THE PROGRAM (INCLUDING BUT NOT LIMITED TO LOSS OF DATA OR DATA BEING RENDERED INACCURATE OR LOSSES SUSTAINED BY YOU OR THIRD PARTIES OR A FAILURE OF THE PROGRAM TO OPERATE WITH ANY OTHER PROGRAMS), EVEN IF SUCH HOLDER OR OTHER PARTY HAS BEEN ADVISED OF THE POSSIBILITY OF SUCH DAMAGES.

END OF TERMS AND CONDITIONS

How to Apply These Terms to Your New Programs

If you develop a new program, and you want it to be of the greatest possible use to the public, the best way to achieve this is to make it free software which everyone can redistribute and change under these terms.

To do so, attach the following notices to the program. It is safest to attach them to the start of each source file to most effectively convey the exclusion of warranty; and each file should have at least the "copyright" line and a pointer to where the full notice is found.

<one line to give the program's name and a brief idea of what it does.>

Copyright (C) <year> <name of author>

This program is free software; you can redistribute it and/or modify it under the terms of the GNU General Public License as published by the Free Software Foundation; either version 2 of the License, or (at your option) any later version.

This program is distributed in the hope that it will be useful, but WITHOUT ANY WARRANTY; without even the implied warranty of MERCHANTABILITY or FITNESS FOR A PARTICULAR PURPOSE. See the GNU General Public License for more details.

You should have received a copy of the GNU General Public License along with this program; if not, write to the Free Software Foundation, Inc., 51 Franklin Street, Fifth Floor, Boston, MA 02110-1301 USA.

Also add information on how to contact you by electronic and paper mail.

If the program is interactive, make it output a short notice like this when it starts in an interactive mode:

Gnomovision version 69, Copyright (C) year name of author Gnomovision comes with ABSOLUTELY NO WARRANTY; for details type `show w'. This is free software, and you are welcome to redistribute it under certain conditions; type `show c' for details.

The hypothetical commands `show w' and `show c' should show the appropriate parts of the General Public License. Of course, the commands you use may be called something other than `show w' and `show c'; they could even be mouse-clicks or menu items--whatever suits your program.

You should also get your employer (if you work as a programmer) or your school, if any, to sign a "copyright disclaimer" for the program, if necessary. Here is a sample; alter the names:

Yoyodyne, Inc., hereby disclaims all copyright interest in the program
`Gnomovision' (which makes passes at compilers) written by James Hacker.

<signature of Ty Coon>, 1 April 1989

Ty Coon, President of Vice

This General Public License does not permit incorporating your program into proprietary programs. If your program is a subroutine library, you may consider it more useful to permit linking proprietary applications with the library. If this is what you want to do, use the GNU Lesser General Public License instead of this License.

GNU LGPL

This projector product includes the open source software programs which apply the GNU Lesser General Public License Version 2 or later version ("LGPL Programs").

We provide the source code of the LGPL Programs until five (5) years after the discontinuation of same model of this projector product.

If you desire to receive the source code of the LGPL Programs, please see the "EPSON Projector Contact List" in the User's Guide, and contact the customer support of your region.

These LGPL Programs are WITHOUT ANY WARRANTY; without even the implied warranty of MERCHANTABILITY AND FITNESS FOR A PARTICULAR PURPOSE. See the GNU General Public License for more details.

The list of LGPL Programs is as follows and the names of author are described in the source code of the LGPL Programs.

LGPL Programs

glibc-2.10

SDL-1.2.13

SDL-Image

The GNU Lesser General Public License Version 2 is as follows. You also can see the GNU Lesser General Public License Version 2 at <http://www.gnu.org/licenses/>.

GNU LESSER GENERAL PUBLIC LICENSE

Version 2.1, February 1999

Copyright (C) 1991, 1999 Free Software Foundation, Inc. 51 Franklin Street, Fifth Floor, Boston, MA 02110-1301 USA Everyone is permitted to copy and distribute verbatim copies of this license document, but changing it is not allowed.

[This is the first released version of the Lesser GPL. It also counts as the successor of the GNU Library Public License, version 2, hence the version number 2.1.]

Preamble

The licenses for most software are designed to take away your freedom to share and change it. By contrast, the GNU General Public Licenses are intended to guarantee your freedom to share and change free software--to make sure the software is free for all its users.

This license, the Lesser General Public License, applies to some specially designated software packages--typically libraries--of the Free Software Foundation and other authors who decide to use it. You can use it too, but we suggest you first think carefully about whether this license or the ordinary General Public License is the better strategy to use in any particular case, based on the explanations below.

When we speak of free software, we are referring to freedom of use, not price. Our General Public Licenses are designed to make sure that you have the freedom to distribute copies of free software (and charge for this service if you wish); that you receive source code or can get it if you want it; that you can change the software and use pieces of it in new free programs; and that you are informed that you can do these things.

To protect your rights, we need to make restrictions that forbid distributors to deny you these rights or to ask you to surrender these rights. These restrictions translate to certain responsibilities for you if you distribute copies of the library or if you modify it.

For example, if you distribute copies of the library, whether gratis or for a fee, you must give the recipients all the rights that we gave you. You must make sure that they, too, receive or can get the source code. If you link other code with the library, you must provide complete object files to the recipients, so that they can relink them with the library after making changes to the library and recompiling it. And you must show them these terms so they know their rights.

We protect your rights with a two-step method: (1) we copyright the library, and (2) we offer you this license, which gives you legal permission to copy, distribute and/or modify the library.

To protect each distributor, we want to make it very clear that there is no warranty for the free library. Also, if the library is modified by someone else and passed on, the recipients should know that what they have is not the original version, so that the original author's reputation will not be affected by problems that might be introduced by others.

Finally, software patents pose a constant threat to the existence of any free program. We wish to make sure that a company cannot effectively restrict the users of a free program by obtaining a restrictive license from a patent holder. Therefore, we insist that any patent license obtained for a version of the library must be consistent with the full freedom of use specified in this license.

Most GNU software, including some libraries, is covered by the ordinary GNU General Public License. This license, the GNU Lesser General Public License, applies to certain designated libraries, and is quite different from the ordinary General Public License. We use this license for certain libraries in order to permit linking those libraries into non-free programs.

When a program is linked with a library, whether statically or using a shared library, the combination of the two is legally speaking a combined work, a derivative of the original library. The ordinary General Public License therefore permits such linking only if the entire combination fits its criteria of freedom. The Lesser General Public License permits more lax criteria for linking other code with the library.

We call this license the "Lesser" General Public License because it does Less to protect the user's freedom than the ordinary General Public License. It also provides other free software developers Less of an advantage over competing non-free programs. These disadvantages are the reason we use the ordinary General Public License for many libraries. However, the Lesser license provides advantages in certain special circumstances.

For example, on rare occasions, there may be a special need to encourage the widest possible use of a certain library, so that it becomes a de-facto standard. To achieve this, non-free programs must be allowed to use the library. A more frequent case is that a free library does the same job as widely used non-free libraries. In this case, there is little to gain by limiting the free library to free software only, so we use the Lesser General Public License.

In other cases, permission to use a particular library in non-free programs enables a greater number of people to use a large body of free software. For example, permission to use the GNU C Library in non-free programs enables many more people to use the whole GNU operating system, as well as its variant, the GNU/Linux operating system.

Although the Lesser General Public License is Less protective of the users' freedom, it does ensure that the user of a program that is linked with the Library has the freedom and the wherewithal to run that program using a modified version of the Library.

The precise terms and conditions for copying, distribution and modification follow. Pay close attention to the difference between a "work based on the library" and a "work that uses the library". The former contains code derived from the library, whereas the latter must be combined with the library in order to run.

GNU LESSER GENERAL PUBLIC LICENSE TERMS AND CONDITIONS FOR COPYING, DISTRIBUTION AND MODIFICATION

0. This License Agreement applies to any software library or other program which contains a notice placed by the copyright holder or other authorized party saying it may be distributed under the terms of this Lesser General Public License (also called "this License"). Each licensee is addressed as "you".

A "library" means a collection of software functions and/or data prepared so as to be conveniently linked with application programs (which use some of those functions and data) to form executables.

The "Library", below, refers to any such software library or work which has been distributed under these terms. A "work based on the Library" means either the Library or any derivative work under copyright law: that is to say, a work containing the Library or a portion of it, either verbatim or with modifications and/or translated straightforwardly into another language. (Hereinafter, translation is included without limitation in the term "modification".)

"Source code" for a work means the preferred form of the work for making modifications to it. For a library, complete source code means all the source code for all modules it contains, plus any associated interface definition files, plus the scripts used to control compilation and installation of the library.

Activities other than copying, distribution and modification are not covered by this License; they are outside its scope. The act of running a program using the Library is not restricted, and output from such a program is covered only if its contents constitute a work based on the Library (independent of the use of the Library in a tool for writing it). Whether that is true depends on what the Library does and what the program that uses the Library does.

1. You may copy and distribute verbatim copies of the Library's complete source code as you receive it, in any medium, provided that you conspicuously and appropriately publish on each copy an appropriate copyright notice and disclaimer of warranty; keep intact all the notices that refer to this License and to the absence of any warranty; and distribute a copy of this License along with the Library.

You may charge a fee for the physical act of transferring a copy, and you may at your option offer warranty protection in exchange for a fee.

2. You may modify your copy or copies of the Library or any portion of it, thus forming a work based on the Library, and copy and distribute such modifications or work under the terms of Section 1 above, provided that you also meet all of these conditions:

- a) The modified work must itself be a software library.
- b) You must cause the files modified to carry prominent notices stating that you changed the files and the date of any change.
- c) You must cause the whole of the work to be licensed at no charge to all third parties under the terms of this License.
- d) If a facility in the modified Library refers to a function or a table of data to be supplied by an application program that uses the facility, other than as an argument passed when the facility is invoked, then you must make a good faith effort to ensure that, in the event an application does not supply such function or table, the facility still operates, and performs whatever part of its purpose remains meaningful.

(For example, a function in a library to compute square roots has a purpose that is entirely well-defined independent of the application. Therefore, Subsection 2d requires that any application-supplied function or table used by this function must be optional: if the application does not supply it, the square root function must still compute square roots.)

These requirements apply to the modified work as a whole. If identifiable sections of that work are not derived from the Library, and can be reasonably considered independent and separate works in themselves, then this License, and its terms, do not apply to those sections when you distribute them as separate works. But when you distribute the same sections as part of a whole which is a work based on the Library, the distribution of the whole must be on the terms of this License, whose permissions for other licensees extend to the entire whole, and thus to each and every part regardless of who wrote it.

Thus, it is not the intent of this section to claim rights or contest your rights to work written entirely by you; rather, the intent is to exercise the right to control the distribution of derivative or collective works based on the Library.

In addition, mere aggregation of another work not based on the Library with the Library (or with a work based on the Library) on a volume of a storage or distribution medium does not bring the other work under the scope of this License.

3. You may opt to apply the terms of the ordinary GNU General Public License instead of this License to a given copy of the Library. To do this, you must alter all the notices that refer to this License, so that they refer to the ordinary GNU General Public License, version 2, instead of to this License. (If a newer version than version 2 of the ordinary GNU General Public License has appeared, then you can specify that version instead if you wish.) Do not make any other change in these notices.

Once this change is made in a given copy, it is irreversible for that copy, so the ordinary GNU General Public License applies to all subsequent copies and derivative works made from that copy.

This option is useful when you wish to copy part of the code of the Library into a program that is not a library.

4. You may copy and distribute the Library (or a portion or derivative of it, under Section 2) in object code or executable form under the terms of Sections 1 and 2 above provided that you accompany it with the complete corresponding machine-readable source code, which must be distributed under the terms of Sections 1 and 2 above on a medium customarily used for software interchange.

If distribution of object code is made by offering access to copy from a designated place, then offering equivalent access to copy the source code from the same place satisfies the requirement to distribute the source code, even though third parties are not compelled to copy the source along with the object code.

5. A program that contains no derivative of any portion of the Library, but is designed to work with the Library by being compiled or linked with it, is called a "work that uses the Library". Such a work, in isolation, is not a derivative work of the Library, and therefore falls outside the scope of this License.

However, linking a "work that uses the Library" with the Library creates an executable that is a derivative of the Library (because it contains portions of the Library), rather than a "work that uses the library". The executable is therefore covered by this License. Section 6 states terms for distribution of such executables.

When a "work that uses the Library" uses material from a header file that is part of the Library, the object code for the work may be a derivative work of the Library even though the source code is not. Whether this is true is especially significant if the work can be linked without the Library, or if the work is itself a library. The threshold for this to be true is not precisely defined by law.

If such an object file uses only numerical parameters, data structure layouts and accessors, and small macros and small inline functions (ten lines or less in length), then the use of the object file is unrestricted, regardless of whether it is legally a derivative work. (Executables containing this object code plus portions of the Library will still fall under Section 6.)

Otherwise, if the work is a derivative of the Library, you may distribute the object code for the work under the terms of Section 6. Any executables containing that work also fall under Section 6, whether or not they are linked directly with the Library itself.

6. As an exception to the Sections above, you may also combine or link a "work that uses the Library" with the Library to produce a work containing portions of the Library, and distribute that work under terms of your choice, provided that the terms permit modification of the work for the customer's own use and reverse engineering for debugging such modifications.

You must give prominent notice with each copy of the work that the Library is used in it and that the Library and its use are covered by this License. You must supply a copy of this License. If the work during execution displays copyright notices, you must include the copyright notice for the Library among them, as well as a reference directing the user to the copy of this License. Also, you must do one of these things:

- a) Accompany the work with the complete corresponding machine-readable source code for the Library including whatever changes were used in the work (which must be distributed under Sections 1 and 2 above); and, if the work is an executable linked with the Library, with the complete machine-readable "work that uses the Library", as object code and/or source code, so that the user can modify the Library and then relink to produce a modified executable containing the modified Library. (It is understood that the user who changes the contents of definitions files in the Library will not necessarily be able to recompile the application to use the modified definitions.)
- b) Use a suitable shared library mechanism for linking with the Library. A suitable mechanism is one that (1) uses at run time a copy of the library already present on the user's computer system, rather than copying library functions into the executable, and (2) will operate properly with a modified version of the library, if the user installs one, as long as the modified version is interface-compatible with the version that the work was made with.
- c) Accompany the work with a written offer, valid for at least three years, to give the same user the materials specified in Subsection 6a, above, for a charge no more than the cost of performing this distribution.

- d) If distribution of the work is made by offering access to copy from a designated place, offer equivalent access to copy the above specified materials from the same place.
- e) Verify that the user has already received a copy of these materials or that you have already sent this user a copy.

For an executable, the required form of the "work that uses the Library" must include any data and utility programs needed for reproducing the executable from it. However, as a special exception, the materials to be distributed need not include anything that is normally distributed (in either source or binary form) with the major components (compiler, kernel, and so on) of the operating system on which the executable runs, unless that component itself accompanies the executable.

It may happen that this requirement contradicts the license restrictions of other proprietary libraries that do not normally accompany the operating system. Such a contradiction means you cannot use both them and the Library together in an executable that you distribute.

7. You may place library facilities that are a work based on the Library side-by-side in a single library together with other library facilities not covered by this License, and distribute such a combined library, provided that the separate distribution of the work based on the Library and of the other library facilities is otherwise permitted, and provided that you do these two things:
 - a) Accompany the combined library with a copy of the same work based on the Library, uncombined with any other library facilities. This must be distributed under the terms of the Sections above.
 - b) Give prominent notice with the combined library of the fact that part of it is a work based on the Library, and explaining where to find the accompanying uncombined form of the same work.
8. You may not copy, modify, sublicense, link with, or distribute the Library except as expressly provided under this License. Any attempt otherwise to copy, modify, sublicense, link with, or distribute the Library is void, and will automatically terminate your rights under this License. However, parties who have received copies, or rights, from you under this License will not have their licenses terminated so long as such parties remain in full compliance.

9. You are not required to accept this License, since you have not signed it. However, nothing else grants you permission to modify or distribute the Library or its derivative works. These actions are prohibited by law if you do not accept this License. Therefore, by modifying or distributing the Library (or any work based on the Library), you indicate your acceptance of this License to do so, and all its terms and conditions for copying, distributing or modifying the Library or works based on it.
10. Each time you redistribute the Library (or any work based on the Library), the recipient automatically receives a license from the original licensor to copy, distribute, link with or modify the Library subject to these terms and conditions. You may not impose any further restrictions on the recipients' exercise of the rights granted herein. You are not responsible for enforcing compliance by third parties with this License.
11. If, as a consequence of a court judgment or allegation of patent infringement or for any other reason (not limited to patent issues), conditions are imposed on you (whether by court order, agreement or otherwise) that contradict the conditions of this License, they do not excuse you from the conditions of this License. If you cannot distribute so as to satisfy simultaneously your obligations under this License and any other pertinent obligations, then as a consequence you may not distribute the Library at all. For example, if a patent license would not permit royalty-free redistribution of the Library by all those who receive copies directly or indirectly through you, then the only way you could satisfy both it and this License would be to refrain entirely from distribution of the Library.

If any portion of this section is held invalid or unenforceable under any particular circumstance, the balance of the section is intended to apply, and the section as a whole is intended to apply in other circumstances.

It is not the purpose of this section to induce you to infringe any patents or other property right claims or to contest validity of any such claims; this section has the sole purpose of protecting the integrity of the free software distribution system which is implemented by public license practices. Many people have made generous contributions to the wide range of software distributed through that system in reliance on consistent application of that system; it is up to the author/donor to decide if he or she is willing to distribute software through any other system and a licensee cannot impose that choice.

This section is intended to make thoroughly clear what is believed to be a consequence of the rest of this License.
12. If the distribution and/or use of the Library is restricted in certain countries either by patents or by copyrighted interfaces, the original copyright holder who places the Library under this License may add an explicit geographical distribution limitation excluding those countries, so that distribution is permitted only in or among countries not thus excluded. In such case, this License incorporates the limitation as if written in the body of this License.
13. The Free Software Foundation may publish revised and/or new versions of the Lesser General Public License from time to time. Such new versions will be similar in spirit to the present version, but may differ in detail to address new problems or concerns.

Each version is given a distinguishing version number. If the Library specifies a version number of this License which applies to it and "any later version", you have the option of following the terms and conditions either of that version or of any later version published by the Free Software Foundation. If the Library does not specify a license version number, you may choose any version ever published by the Free Software Foundation.
14. If you wish to incorporate parts of the Library into other free programs whose distribution conditions are incompatible with these, write to the author to ask for permission. For software which is copyrighted by the Free Software Foundation, write to the Free Software Foundation; we sometimes make exceptions for this. Our decision will be guided by the two goals of preserving the free status of all derivatives of our free software and of promoting the sharing and reuse of software generally.

NO WARRANTY

15. BECAUSE THE LIBRARY IS LICENSED FREE OF CHARGE, THERE IS NO WARRANTY FOR THE LIBRARY, TO THE EXTENT PERMITTED BY APPLICABLE LAW. EXCEPT WHEN OTHERWISE STATED IN WRITING THE COPYRIGHT HOLDERS AND/OR OTHER PARTIES PROVIDE THE LIBRARY "AS IS" WITHOUT WARRANTY OF ANY KIND, EITHER EXPRESSED OR IMPLIED, INCLUDING, BUT NOT LIMITED TO, THE IMPLIED WARRANTIES OF MERCHANTABILITY AND FITNESS FOR A PARTICULAR PURPOSE. THE ENTIRE RISK AS TO THE QUALITY AND PERFORMANCE OF THE LIBRARY IS WITH YOU. SHOULD THE LIBRARY PROVE DEFECTIVE, YOU ASSUME THE COST OF ALL NECESSARY SERVICING, REPAIR OR CORRECTION.

16. IN NO EVENT UNLESS REQUIRED BY APPLICABLE LAW OR AGREED TO IN WRITING WILL ANY COPYRIGHT HOLDER, OR ANY OTHER PARTY WHO MAY MODIFY AND/OR REDISTRIBUTE THE LIBRARY AS PERMITTED ABOVE, BE LIABLE TO YOU FOR DAMAGES, INCLUDING ANY GENERAL, SPECIAL, INCIDENTAL OR CONSEQUENTIAL DAMAGES ARISING OUT OF THE USE OR INABILITY TO USE THE LIBRARY (INCLUDING BUT NOT LIMITED TO LOSS OF DATA OR DATA BEING RENDERED INACCURATE OR LOSSES SUSTAINED BY YOU OR THIRD PARTIES OR A FAILURE OF THE LIBRARY TO OPERATE WITH ANY OTHER SOFTWARE), EVEN IF SUCH HOLDER OR OTHER PARTY HAS BEEN ADVISED OF THE POSSIBILITY OF SUCH DAMAGES.

END OF TERMS AND CONDITIONS

How to Apply These Terms to Your New Libraries

If you develop a new library, and you want it to be of the greatest possible use to the public, we recommend making it free software that everyone can redistribute and change. You can do so by permitting redistribution under these terms (or, alternatively, under the terms of the ordinary General Public License).

To apply these terms, attach the following notices to the library. It is safest to attach them to the start of each source file to most effectively convey the exclusion of warranty; and each file should have at least the "copyright" line and a pointer to where the full notice is found.

<one line to give the library's name and a brief idea of what it does.>

Copyright (C) <year> <name of author>

This library is free software; you can redistribute it and/or modify it under the terms of the GNU Lesser General Public License as published by the Free Software Foundation; either version 2.1 of the License, or (at your option) any later version.

This library is distributed in the hope that it will be useful, but WITHOUT ANY WARRANTY; without even the implied warranty of MERCHANTABILITY or FITNESS FOR A PARTICULAR PURPOSE. See the GNU Lesser General Public License for more details.

You should have received a copy of the GNU Lesser General Public License along with this library; if not, write to the Free Software Foundation, Inc., 51 Franklin Street, Fifth Floor, Boston, MA 02110-1301 USA

Also add information on how to contact you by electronic and paper mail.

You should also get your employer (if you work as a programmer) or your school, if any, to sign a "copyright disclaimer" for the library, if necessary. Here is a sample; alter the names:

Yoyodyne, Inc., hereby disclaims all copyright interest in the library `Frob' (a library for tweaking knobs) written by James Random Hacker.

<signature of Ty Coon>, 1 April 1990

Ty Coon, President of Vice

That's all there is to it!

BSD License (Berkeley Software Distribution License)

This projector product includes the open source software program "University of California, Berkeley License (Berkeley Software Distribution License)" which applies the terms and conditions provided by owner of the copyright to the "BSD License".

The "BSD License" are WITHOUT ANY WARRANTY; without even the implied warranty of MERCHANTABILITY AND FITNESS FOR A PARTICULAR PURPOSE.

List of BSD License programs

busybox-1.13.4

License terms of conditions of each program which are provided by owner of the copyright to the "BSD License" are as follows.

Copyright (c) The Regents of the University of California. All rights reserved.

This code is derived from software contributed to Berkeley by Kenneth Almquist.

Redistribution and use in source and binary forms, with or without modification, are permitted provided that the following conditions are met:

1. Redistributions of source code must retain the above copyright notice, this list of conditions and the following disclaimer.
2. Redistributions in binary form must reproduce the above copyright notice, this list of conditions and the following disclaimer in the documentation and/or other materials provided with the distribution.
3. Neither the name of the University nor the names of its contributors may be used to endorse or promote products derived from this software without specific prior written permission.

THIS SOFTWARE IS PROVIDED BY THE REGENTS AND CONTRIBUTORS "AS IS" AND ANY EXPRESS OR IMPLIED WARRANTIES, INCLUDING, BUT NOT LIMITED TO, THE IMPLIED WARRANTIES OF MERCHANTABILITY AND FITNESS FOR A PARTICULAR PURPOSE ARE DISCLAIMED. IN NO EVENT SHALL THE REGENTS OR CONTRIBUTORS BE LIABLE FOR ANY DIRECT, INDIRECT, INCIDENTAL, SPECIAL, EXEMPLARY, OR CONSEQUENTIAL DAMAGES (INCLUDING, BUT NOT LIMITED TO, PROCUREMENT OF SUBSTITUTE GOODS OR SERVICES; LOSS OF USE, DATA, OR PROFITS; OR BUSINESS INTERRUPTION) HOWEVER CAUSED AND ON ANY THEORY OF LIABILITY, WHETHER IN CONTRACT, STRICT LIABILITY, OR TORT (INCLUDING NEGLIGENCE OR OTHERWISE) ARISING IN ANY WAY OUT OF THE USE OF THIS SOFTWARE, EVEN IF ADVISED OF THE POSSIBILITY OF SUCH DAMAGE.

libjpeg

This projector product includes the open source software program "libjpeg" which applies the terms and conditions provided by owner of the copyright to the "libjpeg".

The "libjpeg" are WITHOUT ANY WARRANTY; without even the implied warranty of MERCHANTABILITY AND FITNESS FOR A PARTICULAR PURPOSE.

List of libjpeg programs

libjpeg-6b

License terms of conditions of each program which are provided by owner of the copyright to the "libjpeg" are as follows.

Copyright (C) 1994-1997, Thomas G. Lane. This file is part of the Independent JPEG Group's software. For conditions of distribution and use, see the accompanying README file.

This distribution contains the sixth public release of the Independent JPEG Group's free JPEG software. You are welcome to redistribute this software and to use it for any purpose, subject to the conditions under LEGAL ISSUES, below.

LEGAL ISSUES

=====

In plain English:

1. We don't promise that this software works. (But if you find any bugs, please let us know!)
2. You can use this software for whatever you want. You don't have to pay us.

3. You may not pretend that you wrote this software. If you use it in a program, you must acknowledge somewhere in your documentation that you've used the IJG code.

In legalese:

The authors make NO WARRANTY or representation, either express or implied, with respect to this software, its quality, accuracy, merchantability, or fitness for a particular purpose. This software is provided "AS IS", and you, its user, assume the entire risk as to its quality and accuracy.

This software is copyright (C) 1991-1998, Thomas G. Lane. All Rights Reserved except as specified below.

Permission is hereby granted to use, copy, modify, and distribute this software (or portions thereof) for any purpose, without fee, subject to these conditions:

- (1) If any part of the source code for this software is distributed, then this README file must be included, with this copyright and no-warranty notice unaltered; and any additions, deletions, or changes to the original files must be clearly indicated in accompanying documentation.
- (2) If only executable code is distributed, then the accompanying documentation must state that "this software is based in part on the work of the Independent JPEG Group".
- (3) Permission for use of this software is granted only if the user accepts full responsibility for any undesirable consequences; the authors accept NO LIABILITY for damages of any kind.

These conditions apply to any software derived from or based on the IJG code, not just to the unmodified library. If you use our work, you ought to acknowledge us.

Permission is NOT granted for the use of any IJG author's name or company name in advertising or publicity relating to this software or products derived from it. This software may be referred to only as "the Independent JPEG Group's software".

We specifically permit and encourage the use of this software as the basis of commercial products, provided that all warranty or liability claims are assumed by the product vendor.

ansi2knr.c is included in this distribution by permission of L. Peter Deutsch, sole proprietor of its copyright holder, Aladdin Enterprises of Menlo Park, CA. ansi2knr.c is NOT covered by the above copyright and conditions, but instead by the usual distribution terms of the Free Software Foundation; principally, that you must include source code if you redistribute it. (See the file ansi2knr.c for full details.) However, since ansi2knr.c is not needed as part of any program generated from the IJG code, this does not limit you more than the foregoing paragraphs do.

The Unix configuration script "configure" was produced with GNU Autoconf. It is copyright by the Free Software Foundation but is freely distributable. The same holds for its supporting scripts (config.guess, config.sub, ltconfig, ltmain.sh). Another support script, install-sh, is copyright by M.I.T. but is also freely distributable.

It appears that the arithmetic coding option of the JPEG spec is covered by patents owned by IBM, AT&T, and Mitsubishi. Hence arithmetic coding cannot legally be used without obtaining one or more licenses. For this reason, support for arithmetic coding has been removed from the free JPEG software. (Since arithmetic coding provides only a marginal gain over the unpatented Huffman mode, it is unlikely that very many implementations will support it.) So far as we are aware, there are no patent restrictions on the remaining code.

The IJG distribution formerly included code to read and write GIF files. To avoid entanglement with the Unisys LZW patent, GIF reading support has been removed altogether, and the GIF writer has been simplified to produce "uncompressed GIFs". This technique does not use the LZW algorithm; the resulting GIF files are larger than usual, but are readable by all standard GIF decoders.

We are required to state that

"The Graphics Interchange Format(c) is the Copyright property of CompuServe Incorporated. GIF(sm) is a Service Mark property of CompuServe Incorporated."

libpng

This projector product includes the open source software program "libpng" which applies the terms and conditions provided by owner of the copyright to the "libpng".

The "libpng" are WITHOUT ANY WARRANTY; without even the implied warranty of MERCHANTABILITY AND FITNESS FOR A PARTICULAR PURPOSE.

List of libpng programs

libpng-1.2.7

License terms of conditions of each program which are provided by owner of the copyright to the "libpng" are as follows.

For conditions of distribution and use, see copyright notice in png.h Copyright (c) 1998-2004 Glenn Randers-Pehrson (Version 0.96 Copyright (c) 1996, 1997 Andreas Dilger) (Version 0.88 Copyright (c) 1995, 1996 Guy Eric Schalnat, Group 42, Inc.)

This copy of the libpng notices is provided for your convenience. In case of any discrepancy between this copy and the notices in the file png.h that is included in the libpng distribution, the latter shall prevail.

COPYRIGHT NOTICE, DISCLAIMER, and LICENSE:

If you modify libpng you may insert additional notices immediately following this sentence.

libpng version 1.2.6, September 12, 2004, is Copyright (c) 2004 Glenn Randers-Pehrson, and is distributed according to the same disclaimer and license as libpng-1.2.5 with the following individual added to the list of Contributing Authors

Cosmin Truta

libpng versions 1.0.7, July 1, 2000, through 1.2.5 - October 3, 2002, are Copyright (c) 2000-2002 Glenn Randers-Pehrson, and are distributed according to the same disclaimer and license as libpng-1.0.6 with the following individuals added to the list of Contributing Authors

Simon-Pierre Cadieux

Eric S. Raymond

Gilles Vollant

and with the following additions to the disclaimer:

There is no warranty against interference with your enjoyment of the library or against infringement. There is no warranty that our efforts or the library will fulfill any of your particular purposes or needs. This library is provided with all faults, and the entire risk of satisfactory quality, performance, accuracy, and effort is with the user.

libpng versions 0.97, January 1998, through 1.0.6, March 20, 2000, are Copyright (c) 1998, 1999 Glenn Randers-Pehrson, and are distributed according to the same disclaimer and license as libpng-0.96, with the following individuals added to the list of Contributing Authors:

Tom Lane

Glenn Randers-Pehrson

Willem van Schaik

libpng versions 0.89, June 1996, through 0.96, May 1997, are Copyright (c) 1996, 1997 Andreas Dilger Distributed according to the same disclaimer and license as libpng-0.88, with the following individuals added to the list of Contributing Authors:

John Bowler

Kevin Bracey

Sam Bushell

Magnus Holmgren

Greg Roelofs

Tom Tanner

libpng versions 0.5, May 1995, through 0.88, January 1996, are Copyright (c) 1995, 1996 Guy Eric Schalnat, Group 42, Inc.

For the purposes of this copyright and license, "Contributing Authors" is defined as the following set of individuals:

Andreas Dilger
Dave Martindale
Guy Eric Schalnat
Paul Schmidt
Tim Wegner

The PNG Reference Library is supplied "AS IS". The Contributing Authors and Group 42, Inc. disclaim all warranties, expressed or implied, including, without limitation, the warranties of merchantability and of fitness for any purpose. The Contributing Authors and Group 42, Inc. assume no liability for direct, indirect, incidental, special, exemplary, or consequential damages, which may result from the use of the PNG Reference Library, even if advised of the possibility of such damage.

Permission is hereby granted to use, copy, modify, and distribute this source code, or portions hereof, for any purpose, without fee, subject to the following restrictions:

1. The origin of this source code must not be misrepresented.
2. Altered versions must be plainly marked as such and must not be misrepresented as being the original source.
3. This Copyright notice may not be removed or altered from any source or altered source distribution.

The Contributing Authors and Group 42, Inc. specifically permit, without fee, and encourage the use of this source code as a component to supporting the PNG file format in commercial products. If you use this source code in a product, acknowledgment is not required but would be appreciated.

A "png_get_copyright" function is available, for convenient use in "about" boxes and the like:

```
printf("%s",png_get_copyright(NULL));
```

Also, the PNG logo (in PNG format, of course) is supplied in the files "pngbar.png" and "pngbar.jpg (88x31) and "pngnow.png" (98x31).

Libpng is OSI Certified Open Source Software. OSI Certified Open Source is a certification mark of the Open Source Initiative.

Glenn Randers-Pehrson
glennrp@users.sourceforge.net
September 12, 2004

zlib

This projector product includes the open source software program "zlib" which applies the terms and conditions provided by owner of the copyright to the "zlib".

The "zlib" are WITHOUT ANY WARRANTY; without even the implied warranty of MERCHANTABILITY AND FITNESS FOR A PARTICULAR PURPOSE.

List of zlib programs

zlib-1.1.4

License terms of conditions of each program which are provided by owner of the copyright to the "zlib" are as follows.

Copyright notice:

(C) 1995-1998 Jean-loup Gailly and Mark Adler

This software is provided 'as-is', without any express or implied warranty. In no event will the authors be held liable for any damages arising from the use of this software.

Permission is granted to anyone to use this software for any purpose, including commercial applications, and to alter it and redistribute it freely, subject to the following restrictions:

1. The origin of this software must not be misrepresented; you must not claim that you wrote the original software. If you use this software in a product, an acknowledgment in the product documentation would be appreciated but is not required.
2. Altered source versions must be plainly marked as such, and must not be misrepresented as being the original software.
3. This notice may not be removed or altered from any source distribution.

Jean-loup Gailly

Mark Adler

jloup@gzip.org

madler@alumni.caltech.edu

If you use the zlib library in a product, we would appreciate *not* receiving lengthy legal documents to sign. The sources are provided for free but without warranty of any kind. The library has been entirely written by Jean-loup Gailly and Mark Adler; it does not include third-party code.

If you redistribute modified sources, we would appreciate that you include in the file ChangeLog history information documenting your changes.

libmd5-rfc

This project product includes the open source software program "libmd5-rfc" which applies the terms and conditions provided by owner of the copyright to the "libmd5-rfc".

The "libmd5-rfc" are WITHOUT ANY WARRANTY; without even the implied warranty of MERCHANTABILITY AND FITNESS FOR A PARTICULAR PURPOSE.

List of libmd5-rfc programs

libmd5-rfc

License terms of conditions of each program which are provided by owner of the copyright to the "libmd5-rfc" are as follows.

Copyright (C) 1999, 2002 Aladdin Enterprises. All rights reserved.

This software is provided 'as-is', without any express or implied warranty. In no event will the authors be held liable for any damages arising from the use of this software.

Permission is granted to anyone to use this software for any purpose, including commercial applications, and to alter it and redistribute it freely, subject to the following restrictions:

1. The origin of this software must not be misrepresented; you must not claim that you wrote the original software. If you use this software in a product, an acknowledgment in the product documentation would be appreciated but is not required.
2. Altered source versions must be plainly marked as such, and must not be misrepresented as being the original software.
3. This notice may not be removed or altered from any source distribution.

L. Peter Deutsch ghost@aladdin.com

Independent implementation of MD5 (RFC 1321).

This code implements the MD5 Algorithm defined in RFC 1321, whose text is available at

<http://www.ietf.org/rfc/rfc1321.txt>

The code is derived from the text of the RFC, including the test suite (section A.5) but excluding the rest of Appendix A. It does not include any code or documentation that is identified in the RFC as being copyrighted.

The original and principal author of md5.h is L. Peter Deutsch <ghost@aladdin.com>. Other authors are noted in the change history that follows (in reverse chronological order):

2002-04-13 lpd Removed support for non-ANSI compilers; removed

references to Ghostscript; clarified derivation from RFC 1321; now handles byte order either statically or dynamically.

1999-11-04 lpd Edited comments slightly for automatic TOC extraction.

1999-10-18 lpd Fixed typo in header comment (ansi2knr rather than md5); added conditionalization for C++ compilation from Martin Purschke <purschke@bnl.gov>.

1999-05-03 lpd Original version.

mDNSResponder

This project product includes the open source software program "mDNSResponder" which applies the following license terms "Apache License Version 2.0, January 2004".

List of "mDNSResponder"

mDNSResponder-107.6 (only mDNSResponderPosix is used)

License terms "Apache License Version 2.0, January 2004" are as follows.

Apache License

Version 2.0, January 2004

<http://www.apache.org/licenses/>

TERMS AND CONDITIONS FOR USE, REPRODUCTION, AND DISTRIBUTION

1. Definitions.

"License" shall mean the terms and conditions for use, reproduction, and distribution as defined by Sections 1 through 9 of this document.

"Licensor" shall mean the copyright owner or entity authorized by the copyright owner that is granting the License.

"Legal Entity" shall mean the union of the acting entity and all other entities that control, are controlled by, or are under common control with that entity. For the purposes of this definition, "control" means (i) the power, direct or indirect, to cause the direction or management of such entity, whether by contract or otherwise, or (ii) ownership of fifty percent (50%) or more of the outstanding shares, or (iii) beneficial ownership of such entity.

"You" (or "Your") shall mean an individual or Legal Entity exercising permissions granted by this License.

"Source" form shall mean the preferred form for making modifications, including but not limited to software source code, documentation source, and configuration files.

"Object" form shall mean any form resulting from mechanical transformation or translation of a Source form, including but not limited to compiled object code, generated documentation, and conversions to other media types.

"Work" shall mean the work of authorship, whether in Source or Object form, made available under the License, as indicated by a copyright notice that is included in or attached to the work (an example is provided in the Appendix below).

"Derivative Works" shall mean any work, whether in Source or Object form, that is based on (or derived from) the Work and for which the editorial revisions, annotations, elaborations, or other modifications represent, as a whole, an original work of authorship. For the purposes of this License, Derivative Works shall not include works that remain separable from, or merely link (or bind by name) to the interfaces of, the Work and Derivative Works thereof.

"Contribution" shall mean any work of authorship, including the original version of the Work and any modifications or additions to that Work or Derivative Works thereof, that is intentionally submitted to Licensor for inclusion in the Work by the copyright owner or by an individual or Legal Entity authorized to submit on behalf of the copyright owner. For the purposes of this definition, "submitted" means any form of electronic, verbal, or written communication sent to the Licensor or its representatives, including but not limited to communication on electronic mailing lists, source code control systems, and issue tracking systems that are managed by, or on behalf of, the Licensor for the purpose of discussing and improving the Work, but excluding communication that is conspicuously marked or otherwise designated in writing by the copyright owner as "Not a Contribution."

"Contributor" shall mean Licensor and any individual or Legal Entity on behalf of whom a Contribution has been received by Licensor and subsequently incorporated within the Work.

2. **Grant of Copyright License.** Subject to the terms and conditions of this License, each Contributor hereby grants to You a perpetual, worldwide, non-exclusive, no-charge, royalty-free, irrevocable copyright license to reproduce, prepare Derivative Works of, publicly display, publicly perform, sublicense, and distribute the Work and such Derivative Works in Source or Object form.
3. **Grant of Patent License.** Subject to the terms and conditions of this License, each Contributor hereby grants to You a perpetual, worldwide, non-exclusive, no-charge, royalty-free, irrevocable (except as stated in this section) patent license to make, have made, use, offer to sell, sell, import, and otherwise transfer the Work, where such license applies only to those patent claims licensable by such Contributor that are necessarily infringed by their Contribution(s) alone or by combination of their Contribution(s) with the Work to which such Contribution(s) was submitted. If You institute patent litigation against any entity (including a cross-claim or counterclaim in a lawsuit) alleging that the Work or a Contribution incorporated within the Work constitutes direct or contributory patent infringement, then any patent licenses granted to You under this License for that Work shall terminate as of the date such litigation is filed.
4. **Redistribution.** You may reproduce and distribute copies of the Work or Derivative Works thereof in any medium, with or without modifications, and in Source or Object form, provided that You meet the following conditions:
 - (a) You must give any other recipients of the Work or Derivative Works a copy of this License; and
 - (b) You must cause any modified files to carry prominent notices stating that You changed the files; and
 - (c) You must retain, in the Source form of any Derivative Works that You distribute, all copyright, patent, trademark, and attribution notices from the Source form of the Work, excluding those notices that do not pertain to any part of the Derivative Works; and
 - (d) If the Work includes a "NOTICE" text file as part of its distribution, then any Derivative Works that You distribute must include a readable copy of the attribution notices contained within such NOTICE file, excluding those notices that do not pertain to any part of the Derivative Works, in at least one of the following places: within a NOTICE text file distributed as part of the Derivative Works; within the Source form or documentation, if provided along with the Derivative Works; or, within a display generated by the Derivative Works, if and wherever such third-party notices normally appear. The contents of the NOTICE file are for informational purposes only and do not modify the License. You may add Your own attribution notices within Derivative Works that You distribute, alongside or as an addendum to the NOTICE text from the Work, provided that such additional attribution notices cannot be construed as modifying the License.

You may add Your own copyright statement to Your modifications and may provide additional or different license terms and conditions for use, reproduction, or distribution of Your modifications, or for any such Derivative Works as a whole, provided Your use, reproduction, and distribution of the Work otherwise complies with the conditions stated in this License.

5. **Submission of Contributions.** Unless You explicitly state otherwise, any Contribution intentionally submitted for inclusion in the Work by You to the Licensor shall be under the terms and conditions of this License, without any additional terms or conditions.
Notwithstanding the above, nothing herein shall supersede or modify the terms of any separate license agreement you may have executed with Licensor regarding such Contributions.
6. **Trademarks.** This License does not grant permission to use the trade names, trademarks, service marks, or product names of the Licensor, except as required for reasonable and customary use in describing the origin of the Work and reproducing the content of the NOTICE file.
7. **Disclaimer of Warranty.** Unless required by applicable law or agreed to in writing, Licensor provides the Work (and each Contributor provides its Contributions) on an "AS IS" BASIS, WITHOUT WARRANTIES OR CONDITIONS OF ANY KIND, either express or implied, including, without limitation, any warranties or conditions of TITLE, NON-INFRINGEMENT, MERCHANTABILITY, or FITNESS FOR A PARTICULAR PURPOSE. You are solely responsible for determining the appropriateness of using or redistributing the Work and assume any risks associated with Your exercise of permissions under this License.
8. **Limitation of Liability.** In no event and under no legal theory, whether in tort (including negligence), contract, or otherwise, unless required by applicable law (such as deliberate and grossly negligent acts) or agreed to in writing, shall any Contributor be liable to You for damages, including any direct, indirect, special, incidental, or consequential damages of any character arising as a result of this License or out of the use or inability to use the Work (including but not limited to damages for loss of goodwill, work stoppage, computer failure or malfunction, or any and all other commercial damages or losses), even if such Contributor has been advised of the possibility of such damages.

9. **Accepting Warranty or Additional Liability.** While redistributing the Work or Derivative Works thereof, You may choose to offer, and charge a fee for, acceptance of support, warranty, indemnity, or other liability obligations and/or rights consistent with this License. However, in accepting such obligations, You may act only on Your own behalf and on Your sole responsibility, not on behalf of any other Contributor, and only if You agree to indemnify, defend, and hold each Contributor harmless for any liability incurred by, or claims asserted against, such Contributor by reason of your accepting any such warranty or additional liability.

END OF TERMS AND CONDITIONS

APPENDIX: How to apply the Apache License to your work.

To apply the Apache License to your work, attach the following boilerplate notice, with the fields enclosed by brackets "[]" replaced with your own identifying information. (Don't include the brackets!) The text should be enclosed in the appropriate comment syntax for the file format. We also recommend that a file or class name and description of purpose be included on the same "printed page" as the copyright notice for easier identification within third-party archives.

Copyright [yyyy][name of copyright owner]

Licensed under the Apache License, Version 2.0 (the "License");

you may not use this file except in compliance with the License.

You may obtain a copy of the License at

<http://www.apache.org/licenses/LICENSE-2.0>

Unless required by applicable law or agreed to in writing, software distributed under the License is distributed on an "AS IS" BASIS, WITHOUT WARRANTIES OR CONDITIONS OF ANY KIND, either express or implied.

See the License for the specific language governing permissions and limitations under the License.

- A**
- A/V Mute 51
 - Abs. Color Temp. 70
 - Air exhaust vent 10
 - Air filter replacement period 106
 - Aspect 40, 72
 - Auto H/V-Keystone 73
 - Auto Iris 39, 70
 - Auto Setup 71
- B**
- Basic menu 78
 - Blackboard 39
 - Brightness 70
- C**
- Ceiling 19, 74
 - Ceiling mount fixing points 12
 - Cleaning 101
 - Cleaning the air filter and air intake vent 101
 - Cleaning the Projector's Surface 101
 - Color Adjustment 70
 - Color Mode 38, 70
 - Color Saturation 70
 - Computer port 11
 - Configuration menu 67
 - Connection mode 79
 - Consumables 110
 - Continuous 51
 - Contrast 70
 - Control panel 13
 - Control Panel Lock 64, 73
 - Cross 54
 - Customized 39
- D**
- Direct Power On 75
 - Display 74
 - Display Background 74
 - Display order 51
 - Display Settings 50
 - Distance 118
 - Document camera 110
 - Dynamic 38
- E**
- Email Address 82
 - ESC/VP21 114
 - Extended menu 74
 - E-Zoom 53
- F**
- Focus button 14
 - Focus ring 10
 - Foot adjust lever 10
 - Freeze 52
 - Front 19, 74
 - Front adjustable foot 10
 - Full Lock 64
- G**
- Gateway Address 79
- H**
- HDMI port 11
 - HDMI Video Range 71
 - Help function 87
 - High Altitude Mode 75
 - How to replace the air filter 106
 - How to replace the lamp 104
- I**
- Image menu 70
 - Indicators 88
 - Info menu 84
 - Input Signal 71, 84
 - IP Address 82
- K**
- Keystone 73
- L**
- Lamp cover 11
 - Lamp hours 84
 - Lamp indicator 88
 - Lamp replacement period 103
 - Language 75
 - Lens Cover Timer 75
 - Link 21L 114
- M**
- Mail Notification 82, 113
 - Mail Notification menu 82
 - Messages 74
 - Monitor Displays 121

- Mouse pointer 54
- Multi-screen 58, 75
- N**
- Network Configuration 76
- Network information 76
- Network menu 76
- Noise Reduction 71
- O**
- Operating temperature 123
- Operation 75
- Optional accessories 110
- Overheating 89
- P**
- Part Names and Functions 10
- Password protect 62
- Password protect sticker 63
- Photo 38
- PJLink 117
- PJLink Password 78
- Pointer 52
- Pointer Shape 73
- Port Number 82
- Position 71
- Power Consumption 73
- Power indicator 88
- Power inlet 11
- Power On Protect 62
- Presentation 38, 45
- Problem Solving 88
- Progressive 71
- Projection 74
- Projector ID 57, 75
- Projector keyword 78
- Projector Name 78
- Projector Setup 111
- Q**
- Quick Corner 73
- R**
- Reading Mail 113
- Rear 19, 74
- Rear feet 12
- Rear screen 19
- Refresh Rate 84
- Remote control 14
- remote control ID 57
- Remote receiver 10, 12
- Replacing batteries 17
- Reset All 85
- Reset menu 83, 84
- Resetting the lamp operating time
..... 85, 106
- Resolution 84
- Rotating images 47
- S**
- Screen size 118
- Screen switching time 51
- Security menu 80
- Security slot 12
- Select Drive 47
- Settings menu 73
- Sharpness 70
- Signal menu 71
- Sleep Mode 75
- Slideshow 46, 49
- SMTP Server 82
- SNMP 113
- Soft keyboard 77
- Source 84
- Source Search 13, 27
- Specifications 123
- Sports 38
- sRGB 38
- SSID 79
- Standby Mode 75
- Startup Screen 74
- Storage temperature 123
- Subnet Mask 79
- Supported Monitor Displays 121
- Sync Info 84
- Sync. 71
- T**
- Temp indicator 88
- Test Pattern 74
- Theatre 38
- Tint 70
- Tracking 71
- U**
- USB (Type A) port 11
- USB (TypeB) port 11
- USB Type B 75
- User Button 73

User's Logo	60
User's Logo Protect	62

V

Video port	11
Video Signal	71, 84
Volume	73

W

Web Browser	111
Web Control	111
Web Control Password	78
Web Remote	111
Whiteboard	39
Wide-screen projection	40
Wireless LAN indicator	10
Wireless LAN menu	79
Wireless LAN Power	79
Wireless LAN system	79
Wireless LAN unit cover	10
Wireless mouse function	54

Z

Zoom ring	10
-----------------	----